

Design and Implementation of Solar Charge Controller for Photovoltaic Systems

Prasoon Kumar¹, Priyaroushan Sinha², Chitragada Roy³, Mousumi Basu⁴

^{1,2,3}Sikkim Manipal Institute of Technology, Sikkim Manipal University

¹prasoonkumar99333@gmail.com

³roychitragada@gmail.com*

⁴Jadavpur University, Department of Power Engineering,

mousumibas@yahoo.com

Abstract: *The paper presents a design of solar charge controller for PV energy system. A voltage regulator circuit, an Over-charging Protection circuit and an Over-discharging Protection circuit design are proposed in this paper. The voltage regulator circuit modulates the voltage variation at the output of solar panel and fed it to the Charging Controller circuit. The Over-charging controller circuit prevents overcharging of battery and helps to increase lifespan of battery. The Over-discharging circuit protects the battery by restricting flow of current from battery to PV panel. The entire model is implemented in hardware and results are observed and analyzed to examine the capability of the Solar Charge Controller*

Keywords: Solar Charge Controller, Battery, Photovoltaic systems

(Article History: Received 18 September 2017 and accepted 21 April 2018)

1. Introduction

Now a days it is very difficult to fulfil energy demand of world with the help of conventional energy sources due to various environmental problem. In order to reduce dependence on conventional sources of energy and to overcome energy crisis in the world focus has been made on the fields of renewable energy. Solar energy is a very popular source of renewable energy[1].

A Photovoltaic (PV) system consist of a PV array which absorbs sun light and convert it to electricity. Throughout the day depending on temperature and solar irradiance level the voltage generated from the output of PV panel varies drastically[2]-[3]. In PV module voltage can be generated only in day time. Therefore, PV module based standalone system needs energy storage device to store energy during day time so it can be used at night[4].

A charge controller controls the rate of flow of current to or from a battery. It prevents overcharging to limit the energy supplied to the battery by the PV array when the battery is fully charged and may prevent against overvoltage, which reduces battery performance. It over-discharging to disconnect the battery from electrical loads when the battery contains very less charge [5].

In this paper a design of solar charge controller model is proposed. Section II, describes detailed

modeling of different parts of solar charge controller model. Section III, shows hardware implementation of the proposed model and observation of results.

2. Design of solar charge controller

Set The solar charge controller is consists of the following blocks.

- 2.1. Voltage Regulator Circuit
- 2.2. Over-charging Protection Circuit,
- 2.3. Over-discharging Protection Circuit.

Figure1 shows the block diagram of the proposed solar controller circuit.

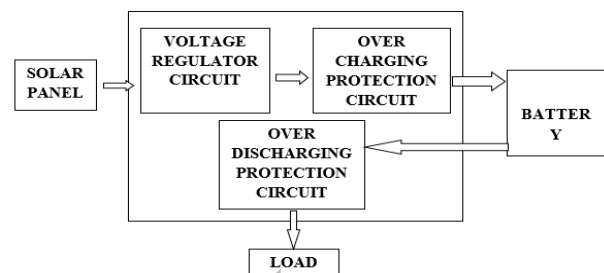

Figure:1. Block Diagram of Solar Charge Controller

2.1 Voltage Regulator circuit

It is required to supply a constant voltage to the charging circuit but due to the variable voltage supplied from the solar panel, a voltage regulator circuit is used in the current model to modulate the variable voltage supply to an almost constant voltage. Irrespective of any output voltage of the solar PV system, this voltage regulator circuit is capable to modulate the output voltage to 13.24 Volt by adjusting the potentiometer arm resistance R_x as shown in figure: 2. The output of which is further fed to the next level of protection circuit.

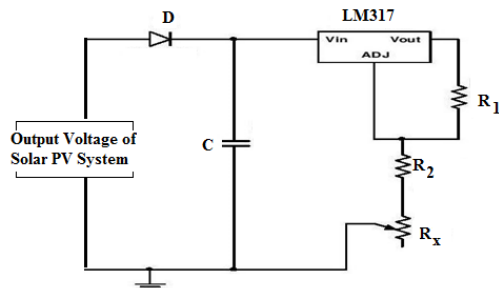

Figure: 2. Voltage Regulator circuit

2.2 Over-charging Protection Circuit:

When a battery gets full charged, further it cannot store any energy. If charge flow to the battery continues, as a result of overcharging the battery overheats and deteriorates fast.

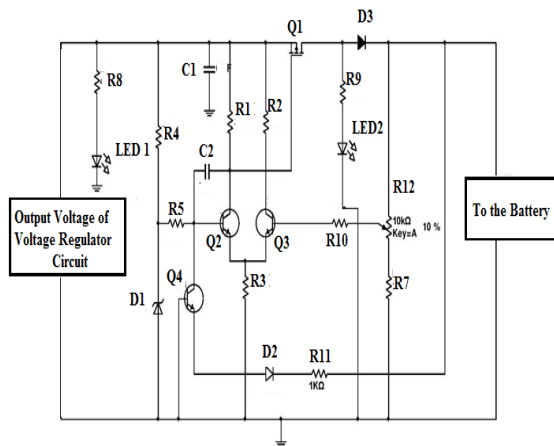

Figure:3. Over-charging Protection Circuit

An overcharging protection circuit is designed to limit excessive charging of battery as shown in fig: 03. The reference voltage is set at 6 V. Here, The LED1 indicates that the solar panel is active. The transistor Q2 and Q3 work as a differential amplifier that amplifies the difference between the reference voltage and the feedback voltage from the arm of potentiometer. The output of the collector Q1 drives

the gate of the MOSFET Q3 which operates as a switch in this circuit. As the battery gets charged the feedback voltage increases. Transistor Q3 senses the signal and accordingly sends gate pulse to MOSFET Q3 through collector of transistor Q2. As a result Q3 turns off. The glowing LED2 is an indicator of charging of battery, once the battery is fully charged it stops glowing. Transistor Q4 is used to protect PV panel by blocking reverse flow of charge from the battery.

2.3 Over-discharging Protection circuit:

This circuit protects the battery against deep discharge (discharge below the minimum voltage) and load against under voltage as shown in figure:4. After discharging battery to the minimum supply voltage circuit disconnects the load from the battery and does not draw any current.

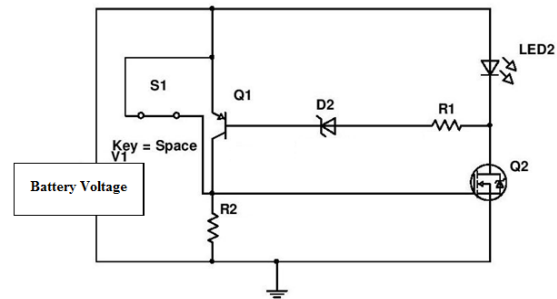

Figure: 4. Circuit Diagram of Over Discharging Protection

3. Hardware implementation and observation of result

The below figure: 5 and figure:6 show, in hardware model at the time of charging V_{gs} (gate source voltage) is approximately -8.77V and at fully charged time V_{gs} is approximately -4.84mV. As a result MOSFET Q1 (as shown in figure 3) is switched off and thus it prevents the battery from over charging.

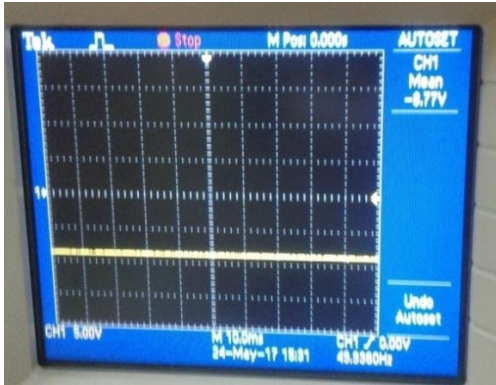

Figure: 5. Gate signal at MOSFET Q1 at the of Time Charging

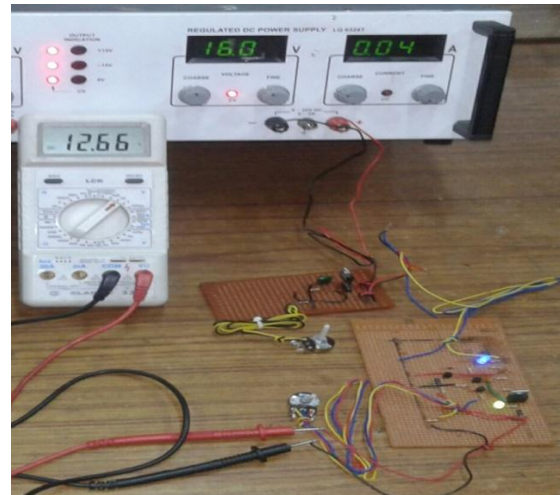

Figure: 7. Observation after Over-charging protection circuit



Figure: 6. Gate signal at MOSFET Q1 when battery is fully charged

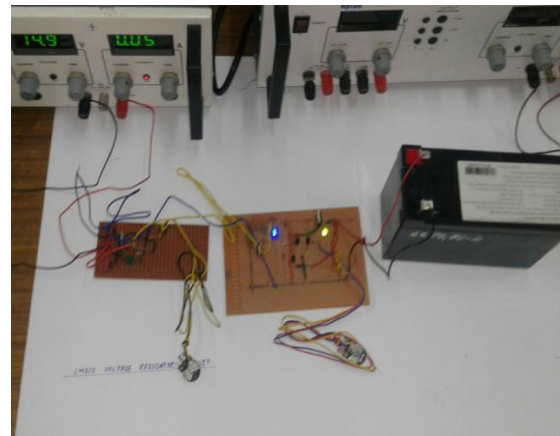

Figure: 8. Hardware Model shows Battery is charging

The below figure:7 shows hardware model of the Voltage regulator circuit connected to Overcharging protection circuit. It can be observed that with the help of voltage regulator circuit, the variable voltage output of PV panel is modulated to around 12.66 Volt voltages and it is supplied to the battery through the overcharging protection circuit. The battery will gradually charge to the full capacity. Once the battery will be fully charged the MOSFET will turn off and further charging will be blocked which can be observed by the glow of green LED in the hardware circuit.

In above figure: 8 demonstrates the schematic of protection that disconnects the battery when the voltage reaches the minimum value. To connect the load one must press S1 (as shown in figure:4). As long as the voltage is sufficiently large, the Q1 and Q2 maintain each other in ON state. When the voltage decreases, the current stops flowing through the Zener diode, which closes Q1 and as well as Q2. Figure:9 and figure:10 show hardware model of over discharging protection circuit.

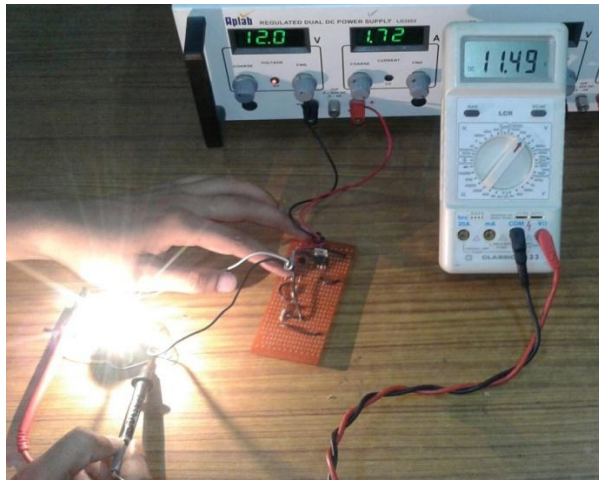

Figure: 9 Hardware model of over-discharging Protection Circuit

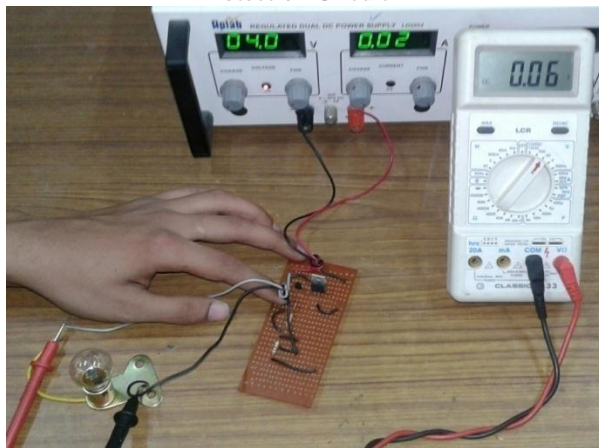

Figure: 10 Hardware model of Over-discharging Protection Circuit at the Time of Discharging Protection

4. Conclusion

A Solar charge controller is an essential part of nearly all power systems that charge batteries. In this paper, hardware model of various parts of solar charge controller circuit is developed. The voltage regulator circuit controls the variable voltage of the solar panel and thus gives a constant output voltage. The overcharging protection circuit is also efficiently works to protect the battery from over charging damage and the over discharging protection circuit prevents the battery from over discharging. Therefore, the hardware circuit of the solar charge controller circuit successfully protects battery from damage and helps to extend the life of battery.

References

- [1] P. A. Jankar and A. S. Patil, "Maximum utilization of solar (renewable energy) by using multiple sensor technology," 2016 International Conference on Signal Processing, Communication, Power and Embedded System (SCOPEs), Paralakhemundi, Odisha, India, 2016, pp. 446-451.
- [2] Weidong Xiao and W. G. Dunford, "A modified adaptive hill climbing MPPT method for photovoltaic power systems," 2004 IEEE 35th Annual Power Electronics Specialists Conference (IEEE Cat. No.04CH37551), 2004, pp. 1957-1963 Vol.3
- [3] A. Ajan and K. P. Kumar, "Performance analysis of OFF-GRID solar photo voltaic system," 2015 International Conference on Circuits, Power and Computing Technologies [ICCPCT-2015], Nagercoil, 2015, pp. 1-5.
- [4] M. Islam and M. A. B. Sarkar, "An efficient smart solar charge controller for standalone energy systems," 2015 International Conference on Electrical Drives and Power Electronics (EDPE), TatraskaLomnica, 2015, pp. 246-251.
- [5] N. Khera et al., "Design of charge controller for solar PV systems," 2015 International Conference on Control, Instrumentation, Communication and Computational Technologies (ICCICCT), Kumaracoil, 2015, pp. 149-153.

AUTHOR PROFILE

Prasoon Kumar has Passed B.Tech in Electrical Engineering at Sikkim Manipal Institute of Technology, Sikkim in the year 2017.

Priyaroushan Sinhas passed B.Tech in Electrical Engineering at Sikkim Manipal Institute of Technology, Sikkim in the year 2017.

Dr. Mousumi Basu, Ph. D, is a professor in Power Engineering Department in Jadavpur University. She has completed her Ph. D from Jadavpur University in the year 2003. Her field of specializations are Power system and Soft Computing Technique.



Chitragada Roy

M.Tech, is an Assistant Professor in the department of Electrical and Electronics Engineering at Sikkim Manipal Institute of Technology, Sikkim. She received her B.E. in Electrical Engineering from NIT, Agartala in the year 2010 and M.tech in Power and Energy System Engineering from NIT, Silchar in the year 2012. Her research interest is in the area of Renewable Energy and FACTS devices, Power System.