

Vehicles Safety System Using Arduino

Parveen Kaur¹, Animesh Das², Manash P. Borah³

^{1,2,3}Department of Electrical and Electronics Engineering, School of Technology, Assam Don Bosco University,
Airport Road, Azara, Guwahati -781017, Assam, INDIA.

¹parveenkaurk10@gmail.com*, ²dasanimesh774@gmail.com, ³mborah1996@gmail.com

Abstract: *Transportation is a basic need of society and with the increasing population; indirectly there are increases in the vehicle density, which may lead to many road accidents resulting in injuries and sometimes lead to death. The aim of our project is to make human driving safer and to overcome accidents. This project is developed by integrating the vibration sensor, alcohol sensor, and ultrasonic sensor with the Arduino board. The vibration sensor used in this project is SW420 that detects the vibrations occur in a car and the data obtained can be utilized to detect an occurrence of an accident. The alcohol sensor used in this project is MQ3, which can detect the alcohol content in human breath. The ultrasonic sensor is used in the project to detect the presence of a vehicle for Anti-collision system. The system also makes use of GPS and GSM for real-time analysis.*

Keywords: Arduino; GSM; GPS; Vibration sensor SW420; Alcohol sensor MQ3; Ultrasonic sensor.

Open Access. Copyright ©Authors(s). Distributed under [Creative Commons Attribution 4.0 International License \(CC-BY\)](https://creativecommons.org/licenses/by/4.0/).
Article history- Received: 30 August 2019 and Accepted: 12 October 2019.

1. Introduction

In this work, an accident location detection system, anti-collision system, and alcohol detection system are incorporated for safer human driving and overcome the accident. In the accident location detection system if any hazard occurs a message containing the location of the accident is sent to the reference contact to take necessary steps to control the situation. The execution of the system is simple as it makes use of GSM and GPS technologies. GPS takes the coordinates of the site of the accident and GSM sends the coordinates to the reference contact. All the controls are made using Arduino as it is the main control unit of the system. The Arduino-based collision detection system is a kind of system that is a fastest-growing safety feature in the automotive industries. Such a system enables vehicles to identify the chances of collision and give visual and audio warning to the driver so that the driver can take necessary action to avoid a collision. For the implementation of this system ultrasonic sensor is used to provide the estimation of the distance between two vehicles.

The rate of drinking and driving accident cases have increased significantly and are likely to emerge as one of the most significant problems in the near future. The alcohol detection system incorporated in this work. The system is designed using an alcohol detector, a device that senses a change in the alcoholic gas content of the surrounding air. The device will then analyze the alcoholic vapors and offer the user some

audiovisual indication of the amount of alcohol present. This device is commonly referred to as a breath analyzer; as it analyzes the alcohol content from a person's breath. The system detects the presence of alcohol content in the vehicle and immediately locks the engine of the vehicle.

The research work done by Addala Suryanarayana Murthy and T. Ravindra [6], is a study where an automated control unit is developed that provides information both to the main server and to the manually registered phone number about where the accident happened (location) in the form of latitude and longitude. This enables emergency services to reach the accident area in time and can rescue the victims of the respective accidents.

In the research work done by Ajit Kumar, Ankit Jaiswal, Neha Jaiswal, and Rahul Sharma [7], to communicate between vehicles running on a highway a wireless technology is applied which will enable the potential to avoid the collision. This paper discusses the method of sharing information about vehicles using laser beam detection. The speed and distance of the vehicles are obtained using BLINDER laser detector according to which commands of driving is decided. This system provides a warning message on the basis of data obtained by the detector. If the distance is within the safety limit, an alert tone is activated. While the distance of vehicles crosses threshold distance, this system will reduce the speed automatically.

In the research work done by Vaishnavi

M, Umadevi. V, Vinothini M., BhaskarRao Y., and Pavithra. S [9], a project is developed by integrating the alcohol sensor with the microcontroller 16F877A. The alcohol sensor used in this project is MQ-2 which to detect the alcohol content in human breath. An ignition system which will produce spark plugs is build up as a prototype to act as the ignition starter over the vehicle’s engine. The ignition system will operate based on the level of blood alcohol content (BAC) from human breaths detected by an alcohol sensor. The main purpose of this project is “Drunk driving detection”.

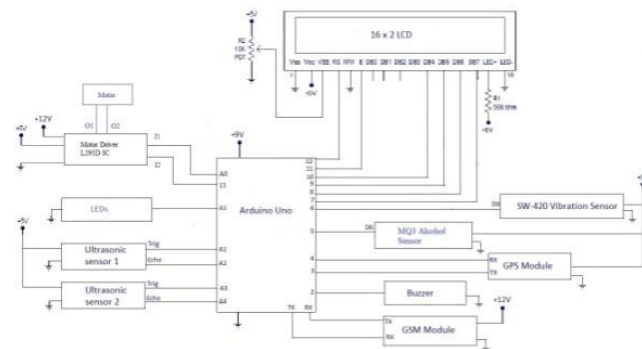

Figure 2: Circuit Diagram

2. Proposed System Design

The designing of smart vehicle using arduino is proposed in this paper which includes accident location detection, anti-collision and alcohol detection features. The block diagram of the proposed work can be represented as:

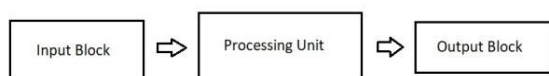

Figure 1: Block Diagram [11]

The input block comprises of the vibration sensor, ultrasonic sensor, alcohol sensor and GPS, which provides the input data to the Arduino. The vibration sensor i.e. SW420 is used for detecting the shock whose sensitivity can be adjusted using the potentiometer on the board, alcohol sensor is used for keeping the track of alcohol levels in the air and the ultrasonic sensor is used to sense the distance between the vehicles. The GPS provides the input location to Arduino in latitudes and longitudes to track the real-time location.

The processing block comprises of Arduino, which acts as the main brain to the system. It accepts the input i.e. from the vibration sensor, alcohol sensor, ultrasonic sensor, and GPS and processes the data according to the requirements and provides the necessary action. The output block comprises of the LCD, buzzer, GSM. Depending upon the output received from the Arduino the different units of the output block will be triggered

3. Circuit Operation

The circuit diagram shown is the feasible diagram for this work.

Here the digital output pin of the vibration sensor and alcohol sensor is connected to the digital input pin 6 and 5 respectively of the Arduino. The V_{cc} of the sensor is connected to +5V supply from the Arduino and ground pin common with Arduino. The RX (receiver) pin and TX (transmitter) pin of the GPS module is connected to pin 4 and 3 of the Arduino respectively. The GPS is power by +5V supply from the Arduino. The RX and TX pin of the GSM module is connected to the TX and RX pin of the Arduino. The GSM module requires a power supply of +12V which will be provided by using the adaptor. The buzzer is connected to A1 pin of the Arduino. The RS pin of the LCD module is connected to digital pin 12 of the Arduino. R/W pin of the LCD is grounded. Enable pin of the LCD module is connected to digital pin 11 of the Arduino. In this project, the LCD module and Arduino are interfaced in the 4-bit mode. This means only four of the digital input lines (DB4 to DB7) of the LCD are used. Digital lines DB4, DB5, DB6, and DB7 are interfaced to digital pins 10, 9, 8 and 7 of the Arduino. The 10K potentiometer is used for adjusting the contrast of the display. 560-ohm resistor R1 limits the current through the backlight LED. The Arduino can be powered through the external power jack provided on the board. +5V required in some other parts of the circuit can be tapped from the 5V source on the Arduino board. The ultrasonic sensor is powered using +5V supply from Arduino, have a common ground. The Trig and Echo pins of the ultrasonic sensor are connected to the pins as shown in the circuit diagram. The Motor Driver IC L293D is connected to the pins A0 and 13 of the Arduino board to receive the input signal. To the output pins of Motor Driver IC, a DC motor is connected to represents as the engine of the car. The Arduino can be also powered from the PC through the USB port.

3.1 Components used for the proposed work

The system is designed using the given components listed below. The system was designed to keep the cost at a bare minimum as well as efficient in performance. The design the system is simple yet compact.

Table 1: List of components

Sl. No.	Components	Specification	Quantity
1.	Arduino Board	Uno	1
2.	GPS	---	1
3.	GSM	800	1
4.	Vibration Sensor	SW420	1
5.	Alcohol Sensor	MQ3	1
6.	Ultrasonic Sensor	---	2
7.	Buzzer	----	1
8.	LEDs	Yellow, Red, Blue	1(each)
9.	Resistor	470Ω, 1K (pot)	1(each)
10.	Adaptor	12V	1

3.2 Algorithms used for the proposed work

As the designed smart vehicle includes three features, i.e., Accident location detection, anti-collision and alcohol detection etc. Hence the following flowcharts represent the algorithm adapted for the designing of the proposed system.

3.3.1 Flow Chart for Accident Location Detection System

The flow chart for the Accident location Detection system is shown below:

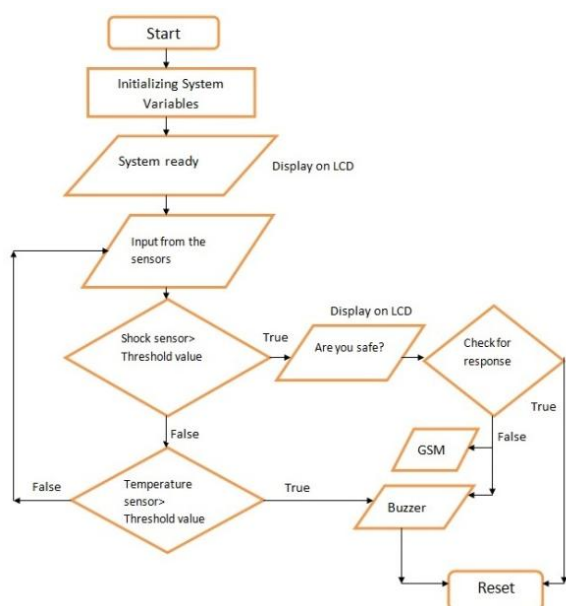

Figure 3(a): Accident Location Detection System

According to the flow chart, the code instructions will be as follows:

1. We will initialize the input pins, output pins and the variables that will be used to store data at different intermediate steps.
2. After the initialization phase is over, there will be a message displayed on the LCD (System ready).
3. Then the system starts reading data from the sensors. The data reading from the sensors is done using the polling technique.
4. After fetching the input from the vibration sensor, the value is first compared with the threshold value of the vibration sensor, if the condition is true i.e. vibration sensor reading is greater than the threshold value then it will go to next step or else it will go to step 8.
5. It will display “Are you safe?” on the LCD for a certain period of time, if the driver is under the condition to take action by themselves then he/she can press the reset button within the appropriate time delay, the system will reboot and no action will be taken.
6. If the driver fails to press the reset button within the appropriate delay, then after the delay automatically the buzzer and GSM will be triggered.
7. To stop the buzzer the system has to be rebooted by pressing the reset button.
8. If the value of the vibration sensor is within the limit, the system then compares the input value of the temperature sensor with the threshold value. If the value of the temperature is higher than the threshold the buzzer is triggered automatically, and if the value lies below the limit then it goes back to step 3.

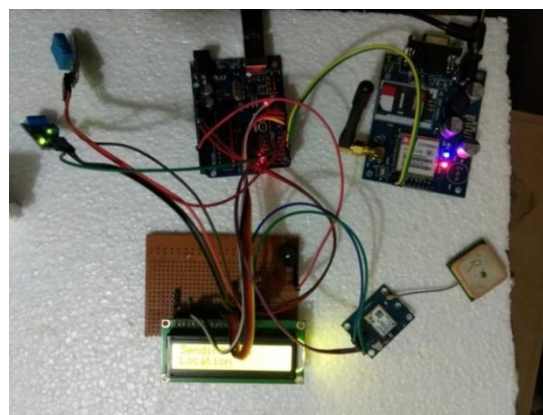

Figure 3(b): Implemented Circuit of Accident Location Detection System [11]

3.3.2 Flow Chart for Anti-collision System

The flow chart for the anti-collision system is shown below:

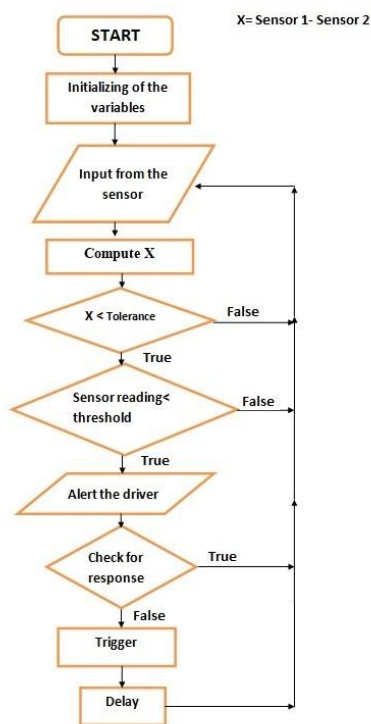

Figure 4(a): Anti-Collision Flow Chart

According to the flow chart, the code instructions will be as follows:

1. We will first initialize the input pins, output pins and the variables that will be used to store data at different intermediate steps.
2. The system starts reading data from the sensors. The data reading from the sensors is done using the polling technique.
3. The difference between the two sensors is computed which is stored in the variable x. If the value of x is greater than the tolerance value it will go back to step 2 or else it will go to the next step.
4. It will check if the sensor reading is less than the tolerance, if yes it will go to the next step or else it will go to step 2.
5. The buzzer will beep to alert the driver that the safe distance limit is being exceeded.
6. The system will check for a response from the drive, if the driver doesn't want the system to take any action, he/she can reset the system by pressing the reset button within the proper delay.
7. If the drive fails to do so in the given time the system will trigger for the set interval of time. After the delay period is over it will return to step 2.

The system can be rebooted at any time by pressing the reset button present is the Arduino board.

3.3.3 Flow Chart for Alcohol Detection System

The flow chart for Alcohol Detection System is shown below:

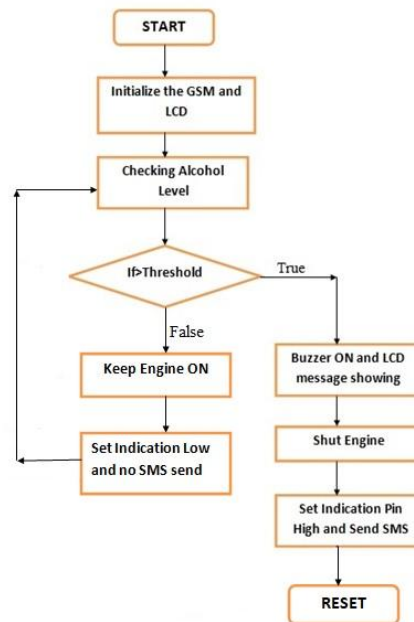

Figure 4(b): Alcohol Detection Flow Chart

According to the flow chart, the code instructions will be as follows:

1. We will first initialize the input pins, output pins and the variables that will be used to store data at different intermediate steps.
2. The system starts reading data from the sensors. The data reading from the sensors is done using the polling technique.
3. The data obtained is stored in an intermediate variable which is later compared with the threshold.
4. If the sensor reading is higher than the threshold it goes to step 7 otherwise it goes to the next step.
5. If the sensor reading is less than the threshold, the engine keeps running, the indication is low, and no message is sent via GSM.
6. The system returns to step 2.
7. If the sensor reading is higher than the threshold the buzzer and LCD are triggered, the engine is shut down, indication pin is set high and the message is sent.

The system can be rebooted at any time by pressing the reset button present is the Arduino board.

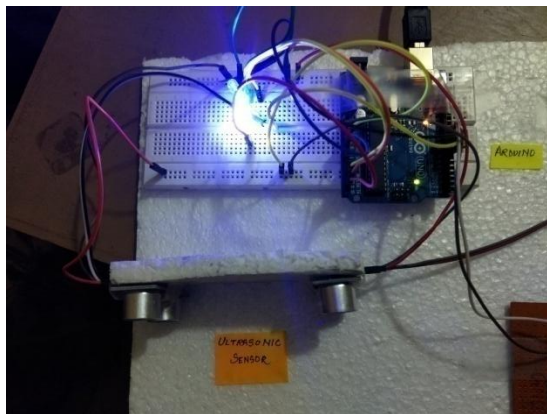

Figure 4(c): Anti-Collision Implemented Circuit

4. Results and Analysis

The output reading of the vibration module is as follows:

Table 2(A): Vibration Module

Sl. No	Vibration Sensor Reading(mV)	LED	Triggering
1	< 1000	Yellow (ON)	---
2	≥ 1000	Red (ON)	GSM, Buzzer

The normal vibration in a car varies from (2000- 3000) mV. But for analysis purpose, the threshold value is set to 1000mV. In a practical situation, the vibration that will be observed in the case of an accident will be much higher.

Under normal conditions, the sensor reading is less than 1000 mV, which is indicated by the yellow LED which represents the normal functioning. Under critical circumstances, the value of the vibration sensor is equal or greater than 1000mV, which is represented by the red LED. And GSM and Buzzer are triggered depending on the conditions specified in the code.

The output reading of the ultrasonic sensor is as follows:

Table 2(B): Anticollision System

Sl.No	Ultrasonic Reading(cm)	LED	Triggering
1	$x < 40$, Sensor reading < 40	Red(ON)	Motor driver triggered
2	$x > 40$	Green (ON)	---

The Ultrasonic Sensor is used to detect the vehicle. The 'x' in the table represents the difference between the two sensor readings. If the sensor reading is less than 40 (Threshold value) and the difference between the sensor reading is also less than 40 then it represents that there is a vehicle in front of the system and the distance between both the vehicle is less than the specified safety distance, as a result, the system will initialize the system controller to avoid collision. If the value is greater than 40, no action will be taken for the anti-collision system.

In the case of Alcohol Detection system, the sensor value decreases as the distance between the sensor and person increases. However, it is also seen that the sensor value changes according to the concentration of alcohol. Therefore, different data have been collected for different situations and represented in the tabular format below.

Table 2(C): Sensor Value for Different Concentration of Alcohol

Sl. No	Sensor Value	Alcohol Concentration
1	210 (Whisky)	42.8
2	270 (Beer)	8

Table 2(D): For 42.8% Alcohol Concentration

Sl. No	Sensor Value	Distance (cm)
1	428	0
2	270	5
3	194	10
4	83	30

Table 2(E): For 8% Alcohol Concentration

Sl. No	Sensor Value	Distance (cm)
1	385	0
2	295	10
3	246	18
4	178	25

Table 2(D) and 2(E) present the variations of the sensor reading with distance for two different levels of alcohol concentration.

5. Conclusion

The main objective of the proposed system was to design a smart vehicle system using Arduino. Here a prototype of the smart vehicle is developed which can be integrated to form an application for installing in smart vehicles in the future. This system will help people receive emergency services

on-time and also reduce the causes of road accidents.

Since smart India is the new trend, every working system is being upgraded to an automatic or smart system then why not a smart vehicle system. In this study, we have taken up only three parameters the system can further be modified by the addition of more sophisticated designs. Some of such sophisticated designs, which can be added in the future, are:

- (i) Speed controller system
- (ii) Pollution control
- (iii) Ignition Control
- (iv) Audio Controllable system and etc.

References

- [1] G. Kiruthikamani, B. Abinayaa, B. Saranya, P. Devi and R. Gayathri, "Smart Vehicle Safety System Using Arduino," *International Journal of Trend in Research and Development*, vol. 3, no. 6, November-December 2016. Available: www.researchgate.net/publication/312031840_Smart_Vehicle_Safety_System_Using_Arduino
- [2] P. Shindalkar, A. F. Shaikh, and C. Mate, "Arduino Based Vehicle Accident Detection System," *International Journal of Innovative Research in Computer and Communication Engineering*, vol. 4, no. 5, April 2017. Available: www.ijrcce.com/upload/2017/april/329_Arduino.pdf
- [3] S. Warankar, S. Nawale, T. Bardeskar, and A. Mhatre, "Arduino based Car Security System," *International Journal of Engineering Technology Science and Research*, vol. 4, no. 4, April 2017. Available: www.ijetsr.com/images/short_pdf/1491820462_dmce820_venue_ijetsr.pdf
- [4] H. Alshamsi, V. Kępuska and H. Alshamsi, "Time Vehicle Tracking Using Arduino Mega," *International Journal of Science and Technology*, vol. 5, no.12, December 2016. Available: www.researchgate.net/publication/319345188_Real_Time_Vehicle_Tracking_Using_Arduino_Mega
- [5] B. Patil, H. Amrite, K. Gaikwad, J. Dighe, and S. Hirleka, "Smart Car Monitoring System Using Arduino," *International Research Journal of Engineering and Technology*, vol. 5, no. 3, March 2018. Available: www.irjet.net/archives/V5/i3/IRJET-V5I3347.pdf
- [6] A. S. Murthy and T. Ravindra, "Accident Location Detection Using Vehicle Tracking System," *International Journal of Advanced Research in Education Technology*, vol. 2, no. 3, July-September 2015. Available: <http://ijaret.com/wp-content/themes/felicity/issues/vol2issue3/adala.pdf>
- [7] A. Kumar, A. Jaiswal, N.a Jaiswal and R. Sharma, "Vehicles Anti-collision System," *International Journal of Computer Applications*, vol. 99, no. 19, August 2014. Available: <https://pdfs.semanticscholar.org/545b/0e292bd2b32ea5b22be8f6bb37cb3818b042.pdf>
- [8] R. K. Moje, A. Kumbhar, R. Shinde and S. Korke, "Automatic Ambulance Rescue System," *International Journal Of Innovative Research in Electrical, Electronics, Instrumentation and Control Engineering*, vol. 4, no. 4, April 2016. Available: <https://www.ijreeice.com/upload/2016/april-16/IJREEICE%2078.pdf>
- [9] M. Vaishnavi, V. Umadevi, M. Vinothini, Y. BhaskarRao and S. Pavithra, "Intelligent Alcohol Detection System for Car," *International Journal of Scientific & Engineering Research*, Vol. 5, no. 11, November-2014. Available: <https://www.ijser.org/researchpaper/INTELLIGENT-ALCOHOL-DETECTION-SYSTEM-FOR-CAR.pdf>
- [10] P. Ingalepatil, P. Barhate, B. Nemade and V. D. Chaudhari, "Alcohol Detection System in Vehicle Using Arduino," *International Research Journal of Engineering and Technology*, vol. 4, no. 6, June 2017. Available: <https://www.irjet.net/archives/V4/i6/IRJET-V4I651.pdf>
- [11] P. Kaur, A. Das, M. P. Borah and S. Dey, "Smart Vehicle System Using Arduino," *ADBU Journal of Electrical and Electronics Engineering*, vol. 3, no. 1, June 2019. Available: <http://journals.dbuniversity.ac.in/ojs/index.php/AJEEE/article/view/658>

Authors' Profiles

Animesh Das is pursuing Bachelor Degree, Department of Electrical and Electronics Engineering, School of Technology, Assam Don Bosco University, Azara, Guwahati.



Parveen Kaur is pursuing Bachelor Degree, Department of Electrical and Electronics Engineering, School of Technology, Assam Don Bosco University, Azara, Guwahati.



Manash Pratim Borah is pursuing Bachelor Degree, Department of Electrical and Electronics Engineering, School of Technology, Assam Don Bosco University, Azara, Guwahati.

