

Design of Electronic Load Controllers of Induction Generators used in Micro Hydro Power Schemes

Deibanehbok Nongdhar

Department of Electrical and Electronics Engineering, Assam Don Bosco University,
Airport Road, Azara, Guwahati -781017, Assam, INDIA.
deibaneh001@gmail.com

Abstract: *This paper describes the use of Electronic Load Controller on micro hydro power scheme in which no separate penstock is required to control the speed of the flow of water. The Electronic Load Controllers (ELC) is an electronic device in which the output of the generator can be maintained constant instead of changing or fluctuating user loads. The ELC maintains a constant generator output by introducing a separate load called ballast load which absorbs the load required by the consumer. This paper also explains and demonstrate a simulation model of an ELC.*

Keywords: Electronic Load Controller (ELC), Micro hydro Scheme, Dump loads or ballast load, self-induction generator, simulation

1. Introduction

Power is one of the fundamental infrastructures all over the world. In the whole wide world, the requirement of electrical energy is increasing day by day. Apart from all the energy sources, renewable sources of energy, which include solar energy, biomass, wind, tidal, geothermal energy and hydroelectric power, play a very important role in resolving the problem of electrical energy supply in many applications. Micro hydroelectric power plants are considered to be the most economical, friendly technology and renewable source of energy, which is helping people in remote or rural areas that do not usually have access to electricity to have a sustainable energy supply [1].

Micro hydro power plant is a type of hydroelectric power plant, which produces up to 100KW of electricity by the implementation of the flow of the water. Due to the higher cost of transmission lines, micro hydro power plant fulfils the demand in energy supply especially in rural areas, which are not connected from the national grid. A micro hydro power plant is always designed at a lower possible cost. Therefore, Electronic Load Controller (ELC) is used instead of a conventional governor. Since the conventional governor is made using mechanical and hydraulic governors to control, the flow of water are uneconomical, high cost, difficult to maintain and construct especially in rural areas. Thus, Electronic Load Controllers the best way of controlling the output of the generator. Similarly, Electronic Load Controllers also increase the simplicity and reliability of Micro hydro power plant [2-3].

2. Electronic Load Controllers (ELC)

Electronic Load Controller is a new technology that was developed during the 1980s. Electronic load controllers control the load on the generator and its main objective is to hold the turbine and generator output at a constant speed instead of fluctuating user demand or water flow. This is achieved by introducing a separate electric load, called ballast load, which absorbs the load required by the consumer. In the case of ELC, if there is an increase in electricity demand, the amount of ballast load is switched OFF. Accordingly, if there is a decrease in electricity demand or an increase in the water flow, the output frequency rises up to a higher level due to the increase in speed of the turbine and generator. Thus, the ELC senses this higher frequency change; the ballast load will have exactly the same amount of power to keep the total load on the generator constant [3].

At full power, ELC is led to run the turbine and generator, or the power can be set manually or possibly at a manually set partial power, and electric load can be kept constant in order to attain the right speed. The function of this ELC is similar to that of the mechanical speed governor as it acts as a mechanical brake and the only difference is that ELC used electric braking. The ELC can be used to sense voltage rather than frequency since the generator is an induction type generator and does not have any internal voltage regulation. So, ELC is much better to use as a voltage regulator [6].

The power devices such as relays, thyristors, MOSFETs, or IGBTs can be used to control the dump loads. With the use of relays, a very basic slow/on/off control can be done, resulting in deterioration of the relay and unstable speed. Some operations by using thyristors are: Simple slow/on/off, individual half cycle control, individual full cycle control method, and phase control method within each half cycle are also used. With the use of MOSFETs or IGBTs, over and above the already mentioned tasks, a high-frequency pulse width modulated control can be implemented. Comparing the uses of IGBTs and MOSFETs, IGBTs have a better power handling to price ratio, while MOSFETs can be used to reduce the size of filter components, i.e., it can work at a higher frequency. By the implementation of all these methods, a constantly changing load on the generator can be attained. The change may be slow or fast but always happen, and that translates into a poor power factor, in which it can be overcome by maintaining an oversized generator. When many dump loads are used, this problem is becoming small; but such control with a single dump load is not encouraged to use. Instead, when high-frequency pulse width modulation is used with proper filtering, this problem can be disappeared.

Some of the advantages of ELCs over mechanical governors are that they are cheaper, quicker and more robust. Similarly, other advantages of electronic load controllers are that they do not require maintenance, as no moving part is required. Their disadvantage is only a waste of water, making them less suitable in case of water shortage, which implies the essentiality of a reservoir in this case [3].

3. Types of ELC Designs

The main type of ELC designs are as follows:

- (i) Binary load regulation
 - (ii) Phase angle regulation
 - (iii) Pulse width regulation
 - (iv) Controlled bridge rectifier
 - (v) Uncontrolled rectifier with a chopper
- **Binary load regulation:** In this case, the ballast load is made up from a switched combination of the binary arrangement of separate resistive loads. Similarly, the total resistive load is divided into a different number of elements wherein the system is bulky, prone to failure, and less reliable [3].

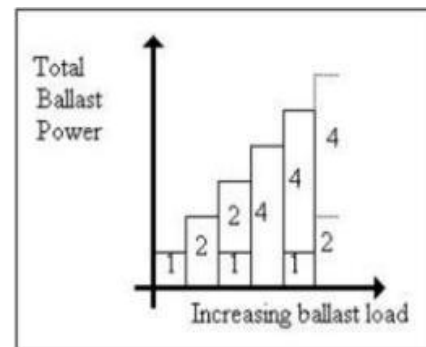

Fig. 1: Binary weighted ballast load [3].

- **Phase angle regulation:** In phase angle regulation, the ballast load consists of a permanently connected single resistive load circuit, which is of magnitude equal or slightly greater than to the full load rated output of the generator. The firing angle of present power electronics switching device such as TRIAC can be adjusted to detect the change in the consumer load resulting in the change of the average voltage. Similarly, in a phase-controlled thyristor-based load controller, as the consumer load is changed from zero to full load, the phase angle of back-to-back-connected thyristors is delayed from 0 to 180. Due to a delay in firing angle, it demands reactive power loading and introduces harmonics in the system. So, it further requires complicated driver circuits [5].
- **Pulse width regulation:** In this type of ELC design, firstly the AC voltage rectified and dump load is then switched ON and OFF with a variable duty cycle. PWM control can have a fast response; and compared to other schemes, they usually have smooth speed control [5].
- **Controlled bridge rectifier:** In the controlled bridge rectifier for single-phase, a firing angle is changed from 0 to 180 and for three-phase, a firing angle is changed from 0 to 120. Similarly, in this scheme, it requires six thyristors and their driving circuits. Hence, it is also complicated, introduces harmonics, and demands reactive power [7].
- **Uncontrolled rectifier with a chopper:** It consists of an uncontrolled rectifier with a chopper [a self-commutating device such as an Insulated-Gate Bipolar Transistor (IGBT)] in series with a dump load. Some of the advantages of this type of ELC design is that it has only one switching device and its required driving circuit. So, this scheme is said to be very simple, cheap, rugged, and reliable. It does not demand reactive power and generates a low value of harmonics. Similarly, this

scheme is inexpensive and compact, as it requires only one dump load [7].

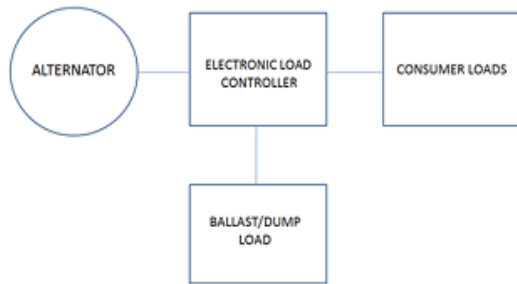

Fig. 2: Control strategy of ELC [5].

4. Design of Electronic Load Controller

In this case, ELC is designed with the used of an uncontrolled rectifier and chopper with a series “dump” load.

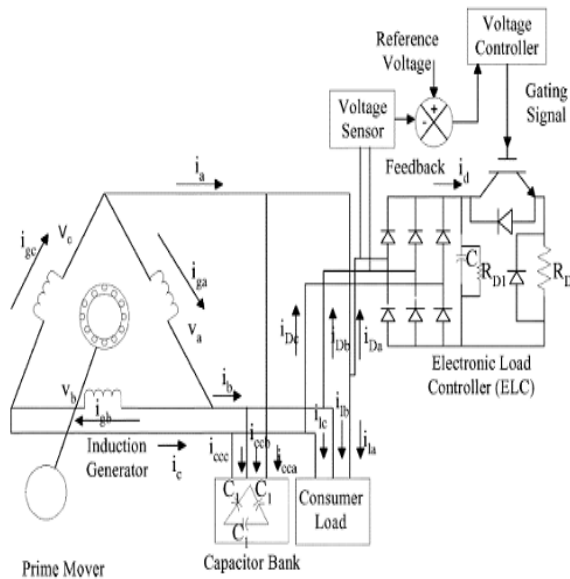

Fig. 3: Electronic Load Controller (ELC) [7].

Based on the design the ELC consists of an uncontrolled rectifier, a filtering capacitor, chopper, and a series resistor dump load. In this case, for the self-excited induction generator, ac terminal voltage is converted to dc by the used of an uncontrolled rectifier. A filtering capacitor (C) is used to smoothen the dc voltage because the uncontrolled rectifier output has ripples. In this circuit, an IGBT is also used as a chopper switch. The chopper switch is then turned ON when the consumer load on SEIG is less than the rated load and turns OFF when consumer load on the self-excited induction generator is at rated value. When the chopper switch is turned ON, and the current is allowed to flow through the dump load and consumes the difference of the generated power and the consumed power (difference power =

generated power - consumed power), resulting in obtaining the constant load on the self-excited induction generator. Hence, constant voltage and constant frequency can be obtained at the load [7].

5. Simulation

Alex Jose and Dr. Jayaprakash P. [7] presented a simulation of the electronic load controller (ELC) has been done by using the simulation software MATLAB. Their MATLAB Simulink model of ELC for self-excited induction generator is shown in Fig. 4.

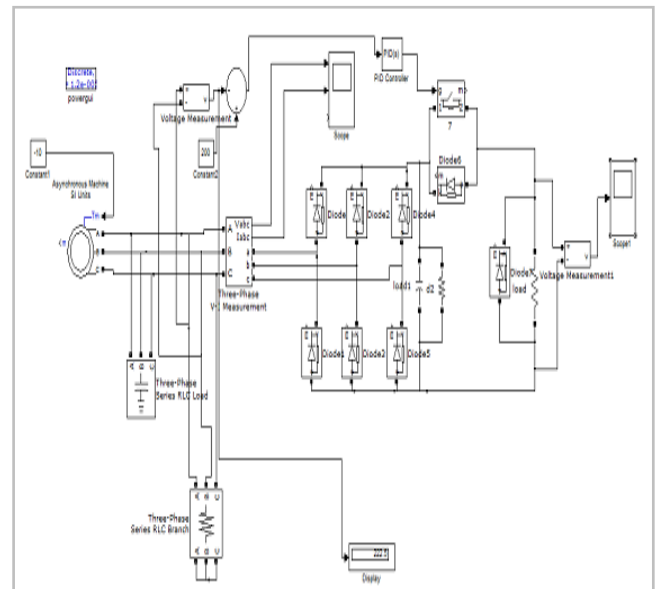

Fig. 4: MATLAB model of ELC connected self-excited induction generator [7].

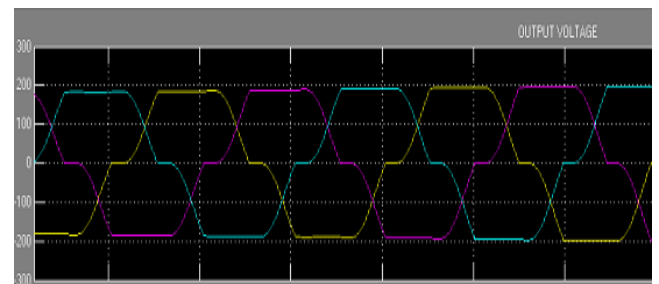

Fig. 5: Simulation results of ELC connected self-excited induction generator [7].

6. Conclusion

This paper presents an exclusive review of the analysis and design of electronic load controller. ELC eliminates the use of conventional governors resulting in making the system more reliable, efficient and economical. Therefore, ELC is the best way of controlling the output of the generator, as conventional governors are uneconomical and difficult to maintain and construct. The Electronic

load control (ELC) was simulated, and the result of ELC connected self- excited induction generator is obtained by using MATLAB simulation software.

References

- [1] S. Singh and A. N. Tiwari, "Voltage and Frequency Controller for Self Excited Induction Generator in Micro Hydro Power Plant: Review", *International Journal of Advanced Research in Electronics and Communication Engineering (IJARECE)*, Vol. 2, Issue 2, February 2013, pp. 214-219. Retrieved from <http://ijarece.org/wp-content/uploads/2013/08/IJARECE-VOL-2-ISSUE-2-214-219.pdf>
- [2] D. Shrestha, A. B. Rajbanshi, K. Shrestha and I. Tamrakar, "Advance Electronic Load Controller for Micro Hydro Power Plant", *Journal of Energy and Power Engineering*, Vol. 8, Issue 10, 2014, pp. 1802-1810. Retrieved from http://flipkarma.com/media_dir/main_documents/18-JEPE14011101.pdf
- [3] C. Nagpal, R. Basheer, A. Thomas, R. Daniel and I. Yousuf, "Analysis and Design of Electronic Load Controllers used in micro hydro power systems", *International Journal of Emerging Technology and Advanced Engineering*, Vol. 4, Special Issue 2, February 2014, pp. 26-31. Retrieved from https://ijetae.com/files/ICITSEM14/IJETAE_ICITSEM_2014_05.pdf
- [4] P. Kapoor, L. Phunchok, S. Kumar and O. P. Rahi, "Frequency Control Of Micro Hydro Power Plant Using Electronic Load Controller", *International Journal of Engineering Research and Applications (IJERA)*, Vol. 2, Issue 4, June-July 2012, pp.733-737. Retrieved from http://www.ijera.com/papers/Vol2_issue4/DN24733737.pdf
- [5] A. Yadav and A. Appan, "Electronic Load Controllers as a Modern Mechanism: A Review", *International Journal of Emerging Technology and Advanced Engineering*, Vol. 5, Issue 6, June 2015, pp. 218-225. Retrieved from http://www.ijetae.com/files/Volume5Issue6/IJETAE_0615_40.pdf
- [6] V. S. Bisht, Y. R. Sood, N. Kushwaha and Suryakant, "Review On Electronic Load Controller", *International Journal of Scientific*

Engineering and Technology, Vol. 1, Issue 2 pp. 93-102, 2012. Retrieved from <http://www.ijset.com/publication/v1/023.pdf>

- [7] A. Jose and P. Jayaprakash, "Power Electronic Control Used in Small Hydro Power System" *International Journal of Electrical Engineering and Technology (IJEET)*, Vol. 5, Issue 12, December 2014, pp. 76-83. Retrieved from <https://goo.gl/khbGpA>