

Stability Improvement of Power System due to Wind Farm and Fault using FACTS Devices

Julene Seka H. Thabah¹, Darihun Sawkmie², Maitshaphrang Lyngdoh³, Smriti Dey⁴

^{1,2,3,4} School of Technology, Assam Don Bosco University
Airport Road, Azara, Guwahati - 781017, Assam, INDIA.

¹julenethabah@gmail.com*, ²dary4km@gmail.com, ³lyngdoh24@gmail.com, ⁴smriti.dey@dbuniversity.ac.in

Abstract: Wind energy is gaining the most interest among a variety of renewable energy resources, but the disadvantage is that wind power generation is intermittent, depending on weather conditions. FACTS devices are used to increase the transient stability on the presence of faults and the integration of renewable sources, like wind energy. Due to continuously varying wind speed components and also due to fault the active and reactive power along with terminal voltage fluctuates continuously. STATCOM and UPFC are two important FACTS devices; provide the desired reactive-power generation and absorption, entirely using electronic processing of the voltage and current waveforms in a voltage source converter (VSC). By connecting STATCOM and UPFC into the lines, the active power, reactive power, and terminal voltage is maintained constant and it also helps to improve the transient stability of the system. STATCOM can control voltage magnitude and, to a small extent, the phase angle in a very short time and UPFC can control voltage magnitude as well as phase angle and therefore, can improve the system performance. In this paper, improvement of transient stability in wind farm under fault have been studied using STATCOM and UPFC in MATLAB SIMULINK software.

Keywords: Transient Stability, Wind farm, FACTS, STATCOM, UPFC.

1. Introduction

Wind power industry is developing rapidly, more and more wind farms are being connected into the power systems to utilize the available wind energy for reducing electricity price and generating clean energy. There will be more significant growth in wind energy. Although the great development in the technology of electricity generation from wind energy, there is only one way of generating electricity from wind energy is to use wind turbines that convert the energy contained in flowing air into electricity [2]. Electric power generation using wind turbines has attracted the attentions of utilities due to high generation capacity and low maintenance cost of such turbines.

The most common type of wind turbine is the fixed speed turbine with squirrel cage induction generator directly connected to the grid. These wind turbines based induction generators require reactive power for compensation. If power is not sufficiently supplied, then the electromagnetic torque of the wind generator decreases significantly. Then the difference between mechanical and electromagnetic torques becomes large, and the wind generator and turbine speeds increase rapidly. As a result, the induction generator becomes unstable, and it requires to be disconnected from the power system. However, the recent trend is to decrease the shutdown operation because a shutdown of a large wind farm can have

a serious effect on the power system operation such as loss of generation and load demand, voltage and frequency variations, power imbalance [3].

2. Theoretical Background

2.1 Introduction

Increasing of power demands and economic growth as well as the rapid increase of CO₂ emission which creates the global warming problem has stimulated the desire for renewable energy sources like wind energy, solar energy etc. Electric power generation using wind turbines has attracted the attentions of utilities due to high generation capacity and low maintenance and cost of such turbines.

The most common type of wind turbine is the fixed speed turbine with squirrel cage induction generator directly connected to the lines. These wind turbines based induction generators require reactive power for compensation. If sufficient reactive power is not supplied, then the electromagnetic torque of the wind generator decreases significantly. Then the difference between mechanical and electromagnetic torques becomes large, and the wind generator and turbine speeds increase rapidly. As a result, the induction generator becomes unstable, and it requires to be disconnected from the power system. In order to improve the transient stability of wind farm,

FACTS devices are used, and simulation is done using MATLAB SIMULINK software.

2.2 Transient stability

Transients are caused by a sudden change of state. The causes can be both external and internal, affecting the other parts too. Whenever there are lightning strikes and itching transients on power lines, the high voltage will be clamped by the lightning arresters to handle the equipment without damage.

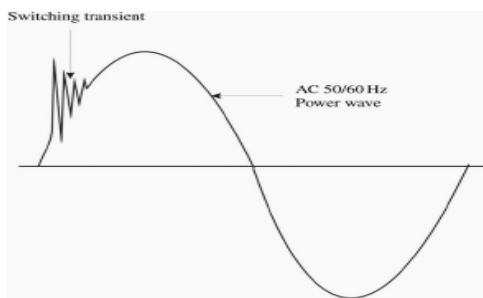

Fig 2.1: Diagram of switching transient

Transient are frequently caused by switching of inductive or capacitive loads, and also another cause include facility load switches, on/off disconnects (on energized lines), capacitor banks switch, tap changing transformers, integration of renewable energy sources with the grid etc. Transient stability is the ability of a power system to maintain synchronism when subjected to a large disturbance. The time frame of interest in transient stability studies is usually 3–5 s following the disturbance. The duration may extend up to 10–20 s for a very large system with dominant inter-area swings. The main aspects of the wind farm that affect the transient stability are:

- a) **Location of wind generator:** Especially when high wind resources are located in one particular area leading to highly modified power flows including increased tie-line flows, critical fault clearing times can be considerably reduced, and additional lines might be required.
- b) **Generator technology:** Variable speed wind generators can improve transient stability margins, when being equipped with low voltage ride-through capability, reactive current boosting and ideally with fast voltage control.
- c) **Connection of large wind farms to lower voltage levels:** The integration of wind generation into sub-transmission and distribution systems has a negative impact on transient stability because the reactive contribution is highly limited due to reactive losses in sub-transmission and distribution systems.

2.3 Wind turbine generator power system

The system used a higher efficiency low-speed permanent magnet wind generator (PMWG) where gear box has been eliminated. In low-speed permanent magnet alternator, the rotor rotates at the same speed as the rotor of the turbine. The Permanent Magnet Alternators (PMA) is directly connected to the wind turbine; this results in a simple mechanical system. The system is comprised of a permanent magnet alternator, rectifier, dc-dc converter, and an inverter as shown in the block diagram below Fig. 2.2. The voltage generated by the PMA machine is rectified using a three-phase passive rectifier, which converts the AC voltage generated by the Permanent Magnet Alternators into a DC voltage. The DC output voltage is boosted to a higher dc voltage. This DC voltage is then converted back into AC voltage using a pulse width modulated (PWM) inverter which is connected to the grid.

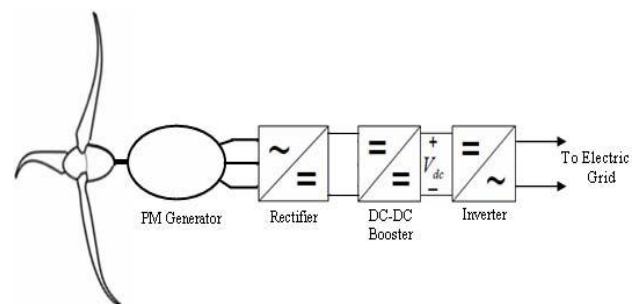

Figure 2.2: Wind Power System Block Diagram

A large number of wind generators connected to form a wind farm. When wind farm generation is given to the grid, it unbalances the current as well as voltage. These can be overcome by using FACTS devices such as STATCOM which is the best method for shunt connected and UPFC which is the best method for combination of both shunt and series-connected devices.

2.4 STATCOM

Static Synchronous Compensator (STATCOM) is a power electronic device that uses force commutated devices like IGBT, GTO etc. to control the reactive power flow through a power network and thereby increasing the stability of power network. It is a shunt device, i.e. it is connected in shunt with the line. It is also known as a Static Synchronous Condenser (STATCON). It is a member of FACTS devices.

2.4.1 Working principle of STATCOM

STATCOM generates or absorbs reactive power to the lines as well as from the lines to compensate for

small voltage variations at the connection point of the wind farm with the grid [7].

To understand the working principle of STATCOM, Let us consider two sources V_1 and V_2 are connected through an impedance $Z = R_a + jX$ as shown in figure 2.3.

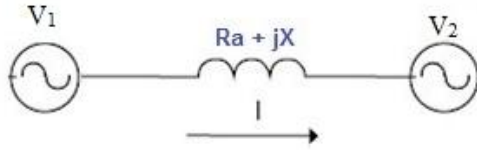

Figure 2.3: Working Principle of STATCOM

By assuming $R_a = 0$, The Reactive Power Flow Q is given as

$$Q = \frac{V_2}{X} [V_1 \cos \delta - V_2]$$

In the above reactive power flow equation, angle δ is the angle between V_1 and V_2 . So by maintaining angle $\delta = 0$ reactive power flow will become

$$Q = \frac{V_2}{X} [V_1 - V_2]$$

Similarly, Active power flow will become

$$P = \frac{V_1 V_2}{X} \sin \delta = 0$$

From the above equations, it is observed that the flow of active power becomes zero and the flow of reactive power depends on $(V_1 - V_2)$. So, for the flow of reactive power there are two possibilities made as shown below:

- 1) If the magnitude of V_1 is more than V_2 , then reactive power will flow from source V_1 to V_2 .
- 2) If the magnitude of V_2 is more than the magnitude of V_1 , reactive power will flow from source V_2 to source V_1 .

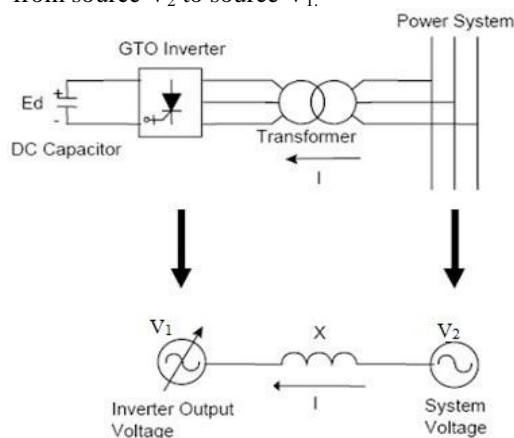

Figure 2.4: A simplified diagram along with an equivalent electrical circuit of STATCOM

As can be seen from the figure above, source V_1 represents the output voltage of the STATCOM. In there is reactive power demand in the power system, STATCOM will increase its

output voltage V_1 while maintaining the phase difference between V_1 and V_2 to zero (it shall be noted here that there will always exist small phase angle between V_1 and V_2 to cater for the leakage impedance drop in the interconnecting Transformer). As $V_1 > V_2$, reactive power will flow from STATCOM to the power system. Thus STATCOM supplies reactive power and acts as the reactive power generator.

Again, if the voltage of power system increases due to load throw off, STATCOM will reduce its output voltage V_1 and therefore will absorb reactive power to stabilize the voltage to a normal value.

2.5 Unified Power Flow Controller

2.5.1 Configuration of UPFC

The UPFC consists of two voltage-source converters; one converter is connected to the power system through a shunt transformer, whereas the other converter is inserted into the transmission line through a series transformer. The converters are connected by a common DC-link where the capacitor is coupled and it allows a bi-directional real power flow between the output terminal of shunt converter and the input terminals of series converter. The basic system configuration of UPFC structure is shown in figure 2.5.

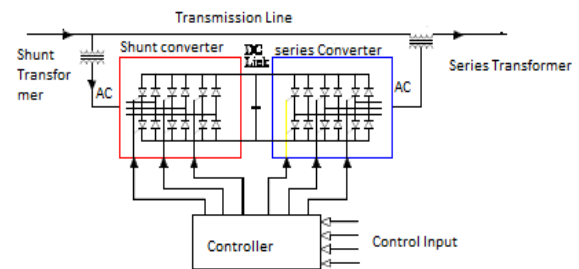

Figure 2.5: UPFC Configuration

A combination of STATCOM and SSSC which are coupled via a common dc link to allow by directional flow of real power between the series output terminals of SSSC and the shunt output terminals of STATCOM, and are controlled to provide concurrent real and reactive series line compensation without an external electrical energy source. It is generalized by synchronous voltage source. UPFC can inject controllable magnitude (V) and angularly unconstrained ($0^\circ \leq \rho \leq 360^\circ$) voltage. From the phasor diagram it is clear that the increasing value of ' V ' will increase the magnitude as well as SPA between sending end and receiving end voltage or vice versa. So UPFC can be used as SPA reduction for power system restoration.

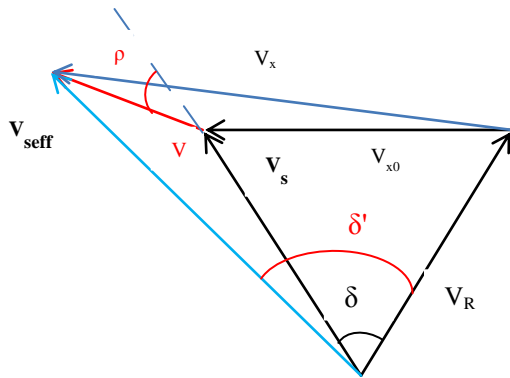

Figure 2.6: Phasor representation of UPFC

a) Shunt converter

The shunt branch of UPFC consists of a DC Capacitor, Shunt converter. It can absorb or generate only reactive power because the output current is in quadrature with the terminal voltage. The shunt-connected branch is used primarily to provide the real power demanded by series converter through the common DC link terminal. Also, it can generate or absorb reactive power independently of the real power, it can be used to regulate the terminal voltage at the sending end; thus shunt converter regulates the voltage at the input terminals of the UPFC. Another role of shunt branch of UPFC is a direct control of the DC capacitor voltage, and consequently an indirect regulation of the real power required by the series UPFC branch. The circuit losses plus the amount of real power required by the series converter have to be supplied by the shunt converter. In some cases desired real power flow from the series converter to shunt converter is possible, in this case, the series converter would supply the required real power plus the losses to the shunt converter. The shunt converter controls the dc voltage and the bus voltage at the shunt converter transformer. This paper, the shunt converter is used to control the sending-end bus voltage magnitude by locally generating and absorbing reactive power.

b) Series converter

The series branch of UPFC is comprised of a DC Capacitor, series converter and a series connected transformer. It can act as a voltage source injected in series to the transmission line through series connected transformer. The real power from series converter to shunt converter and vice versa, and hence it is possible to introduce positive or negative phase shifts between voltage at the source and at the load respectively. The series injected voltage (V_{se}) can have any phase shift with respect to the terminal voltage at the source. Therefore, the area of UPFC becomes the circle limited with a

radius defined by the maximum magnitude of V_{se} . The series converter controls the active and reactive powers flow through transmission line by adjusting the magnitude and phase angle of the series injected voltage. The series converter directly controls real power of the line by controlling the magnitude of the series injected voltage. The series converter is used to generate the voltage and phase shift at the fundamental frequency. This voltage is added directly to terminal voltage by the series connected coupling transformer and in series to the transmission line. The transmission line current passes through the series transformer, and in the process exchanges real and reactive power with the series converter.

2.5.2 Principle of operation of unified power flow controller UPFC

UPFC comprised of two converters VSC1 and VSC2, operated from a DC link provided by a dc storage capacitor. These arrangements operate as an ideal ac to ac converter in which the real power can freely flow either in direction between the ac terminals of the two converters. Each converter can generate or absorb reactive power as its own ac output terminal.

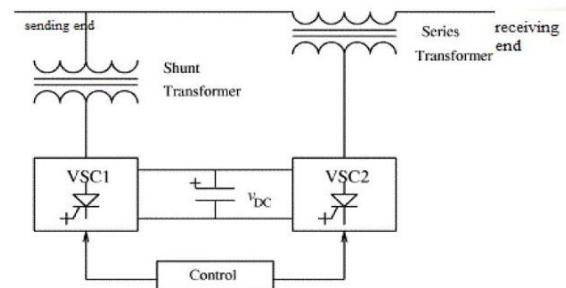

Figure 2.7: Basic UPFC scheme

As shown in the figure above VSC1 is connected to in shunt to the transmission line via a shunt transformer and VSC2 is connected in series through a series transformer. The DC terminal of two VSCs is coupled and this creates a path for active power exchange between the converters. The injected voltage with controllable magnitude and phase angle in series with the line via an injection transformer the main function of UPFC is provided by VSC. This injected voltage act as a synchronous ac voltage source. The current flows through voltage source resulted in reactive and active power exchange between it and the ac system. At the dc terminal the reactive power exchanged is generated internally by the converter. At the ac terminal the real power exchanged is converted into dc power which appears at the dc link as a real power demand and VSC1 is to supply or absorb the real power demanded by converter2 at the common dc link to support real power exchange resulting from

the series voltage injection. The dc link power demand of VSC2 is converted back to ac by VSC1 and coupled to the transmission line bus via shunt connected transformer. In addition, VSC1 can also generate or absorb controllable reactive power if it is required and thereby provide independent shunt reactive compensation for the line. Thus, VSC1 can be operated at a unity power factor or to be controlled to have a reactive power exchange with the line independent of the reactive power exchanged by VSC1. Therefore, there can be no reactive power flow through the UPFC dc link.

2.5.3 STATCOM versus UPFC

- a) STATCOM has the advantage of smaller in dimension as compared to UPFC which is sophisticated.
- b) STATCOM is much simpler unlike UPFC which is more complex.
- c) UPFC has a faster response as compared to STATCOM.
- d) UPFC is more expensive and complicated as compared to others FACTS devices.

2.5.4 Application of STATCOM and UPFC

- a) The networks that have a poor power factor and often poor voltage regulation STATCOM is installed. The most common use of this device is for voltage stability.
- b) Voltage stability is one of the biggest problems in power systems.
- c) UPFC are proposed to improve the overall performance of a DFIG-based WECS during voltage sag and voltage swell events at the grid side.

3. Proposed Method

To improve stability and quality of power due to the instability created by wind generation integration as well as fault in the power systems and the improvement is done by using STATCOM and UPFC.

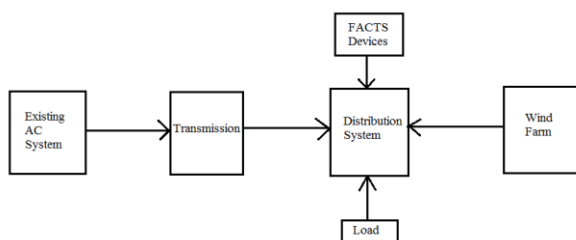

Figure 3.1: Block diagram of the proposed system

A power system with wind generation is designed here. When wind generation is connected with the existing AC system, instability in the system takes place. Thus FACTS device is connected with the system to reduce the voltage and power fluctuations caused due to wind generation and during fault.

Firstly, the STATCOM which is a shunt compensator is connected with the system to improve the stability.

Secondly, UPFC which is a combined compensator is connected with the system to improve the stability of the system.

Here, performance of the STATCOM and UPFC is analyzed with the help of load voltage and power waveforms.

3.1 Simulink model and implementation

The proposed model is designed in SIMULINK tool of MATLAB software. Voltage profile is checked here in normal condition (no fault condition) and in faulted condition with and without STATCOM and UPFC

3.1.1 Transmission line model under normal condition

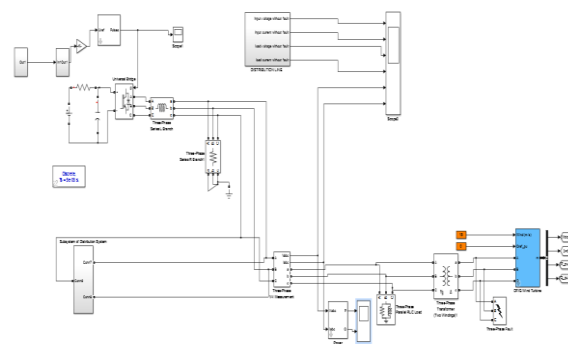

Figure 3.5: Simulation of the system with STATCOM with L-L-L-G fault

In this simulation, a STATCOM is simulated for checking the output and input waveform of the system. In this system, a subsystem is connected into the line which consists of the system simulated without the presence of fault, Wind Turbine and STATCOM. A STATCOM is connected in parallel to the line. Fault of 0.02 to 0.1 sec is applied to this system and is connected in parallel to the system.

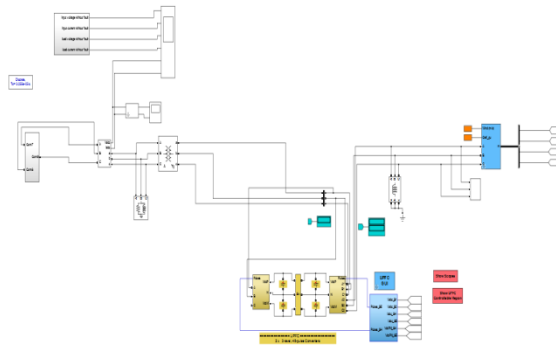

Figure 3.6: Simulation of the system with UPFC

In this simulation, the system with fault is extended by connecting a UPFC and is simulated for checking the output and input waveform of the system. The UPFC consist of two 100MVA, three-level, 48-pulse GTO-based converters, one connected in shunt and one connected in series. The simulation models of the transmission line with UPFC with the application of fault are given in figure 3.6.

4. Results and Analysis

4.1 Voltage waveforms with wind Turbine and STATCOM

During normal condition the voltage level in each phase of both input and load are almost same because of small voltage drop in the system. The magnitude of the load voltage is almost 11kV.

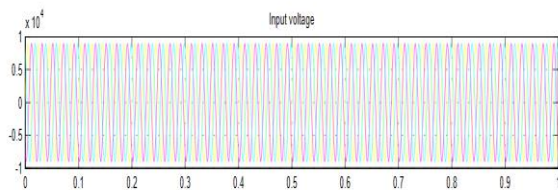

Figure 4.1: Input voltage under normal condition

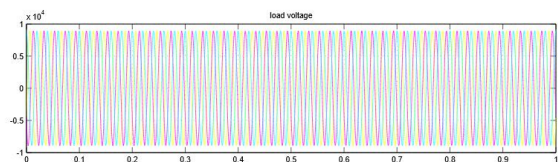

Figure 4.2: Load voltage under normal condition

4.2 Load voltage with fault

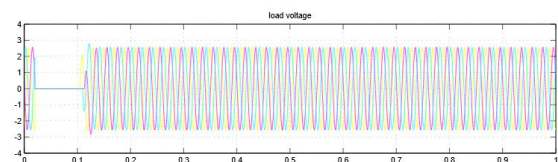

Figure 4.3: Load voltage on the presence of fault

During the application of fault for time duration of 80ms i.e. from 0.02s to 0.1s the load voltage of all the three phase drops to almost zero.

4.3 Load voltage with wind farm and fault

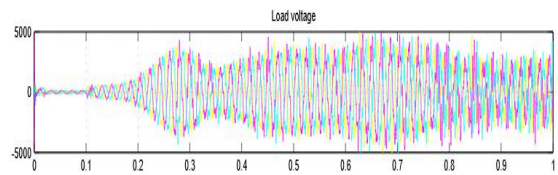

Figure 4.4: Waveform of Load voltage

From the fig 5.4 when a three phase to ground fault is applied with fault resistance of 0.001Ω for time duration of 80ms i.e. from 0.02s to 0.1s the voltage becomes approximately zero.

4.4 Load voltage with STATCOM

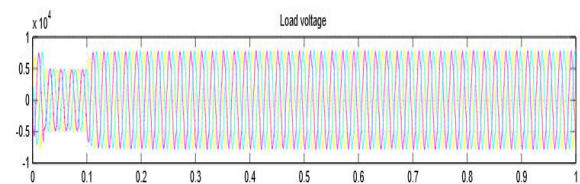

Figure 4.5: Load voltage waveform with STATCOM

Figure 4.5 shows the simulation of the system is carried out by introducing the STATCOM to compensate the voltage sag occurred. From the test model, it is found that after connecting the STATCOM, the load voltage is similar to the supply voltage which indicates that the STATCOM installed in the line is working properly.

4.5 Active and reactive power with STATCOM

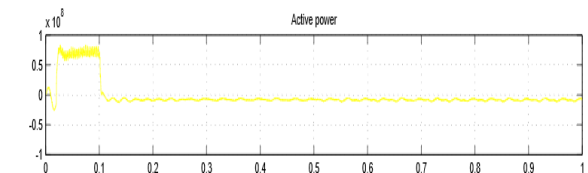

Figure 4.6: Waveform of active power through the line with STATCOM

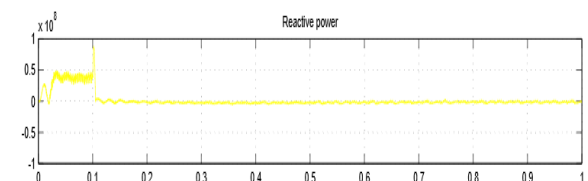

Figure 4.7: Waveform of reactive power through the line with STATCOM

Figure 4.6 and figure 4.7 shows Active and Reactive power in the line, a fault is applied from 0.02s to 0.1s. It is observed from the figures that during fault the active and reactive powers increases from its normal values. Even with the present of STATCOM during fault condition the power increases.

4.6 Load voltage with UPFC

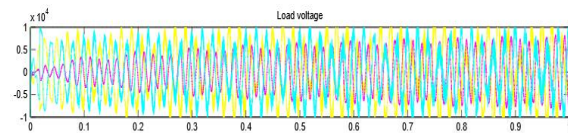

Figure 4.8: Waveform of load voltage through the line with UPFC

Figure 4.8 shows the simulation of the system is carried out by introducing the UPFC to compensate the voltage sag occurred. From the test model, it is found that after connecting the UPFC, the load voltage is similar to the supply voltage even when fault is applied; but a lot of harmonics is present.

4.7 Active and reactive power with UPFC

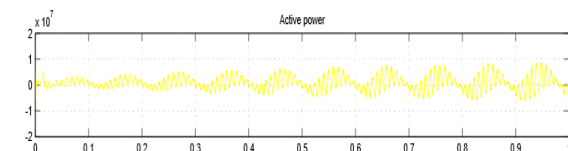

Figure 4.9: Waveform of active power through the line with UPFC

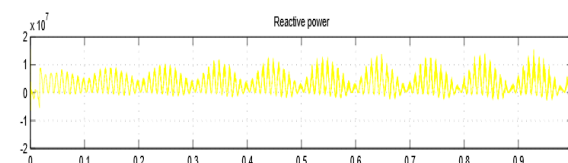

Figure 4.10: Waveform of reactive power through the line with UPFC

Figure 4.9 and figure 4.10 shows Active and Reactive power flows through the line during fault condition i.e. on the application of fault from 0.02s to 0.1s. It is observed from the figures that during fault the active and reactive powers decreases slightly than the active and reactive power when STATCOM is connected with the system, which indicates that incase of power compensation UPFC is better than STATCOM.

5. Conclusion

Wind power which is one of the important renewable sources is considered in order to analyze the effect of this generation on voltage operation

and at the voltage stability limits. It can also be concluded that STATCOM and UPFC can withstand the successive disturbances of the system more efficiently than other FACTS devices. In this system many problems occur, and these problems are compensated by using STATCOM and UPFC. They full fill the reactive power requirement when fault occur in the system, because when fault occurred voltage low and system get unstable. The impacts of the STATCOM on the stability of the system during different fault locations and different fault duration times are studied. The control and performance of UPFC using shunt and series controller is studied. It is observed that during abnormal condition the voltage experience a large amount of fluctuation in comparison to the normal condition. The STATCOM and UPFC are connected to the three-phase transmission system and the results are compared.

It is observed during fault condition the active and reactive powers in case of UPFC reduces slightly more as compared to active and reactive power when STATCOM is connected to the system, which indicates that incase of power compensation, UPFC is better than STATCOM.

6. Limitations

The performance of the STATCOM shows that the power during fault is much high compared to the UPFC, i.e., the designed STATCOM was unable to maintain power through the line constant. The limitation is that harmonics caused due to operation of converters in UPFC is still present in the system. Proper filter circuit can be used to improve the performance of both UPFC.

7. Future Research

In this work, we have designed STATCOM with PI Controller. The performance shows that the load voltage during fault is not exactly same as the voltage before fault so the performance of the STATCOM can be increased by using other controllers like Fuzzy controller. Here performance of UPFC is shown with the use of available blocks in the Simulink library, so the design of UPFC as well as wind farm can also be done using MATLAB Simulink software. Fuzzy controller can also be used for UPFC control to improve the performance of UPFC.

References

- [1] B. Bouhadouza, G. Ahmed and M. Hacene, "Application of STATCOM to Increase Transient Stability of Wind Farm", *American Journal of Electrical Power and Energy*

- Systems*, Vol. 2, Issue No. 2, 2013, pp. 50-56.
Doi: 10.11648/j.epes.20130202.14
- [2] O. Noureldeen, M. Rihan, B. Hasanin, "Stability improvement of fixed speed induction generator wind farm using STATCOM during different fault locations and durations", *Ain Shams Engineering Journal*, Vol. 2, Issue No. 1, 2011, pp.1-10. Doi: 10.1016/j.asej.2011.04.002
- [3] Q. Salem and I. Altawil, "Transient Stability Enhancement of Wind Farm Connected to Grid Supported with FACTS Devices". *International Journal of Electrical Energy*, Vol. 2, Issue No. 2, June 2014. Doi: 10.12720/ijoe.2.2.154-160
- [4] M. T. Hagh, A. R. Milani and A. Lafzi, "Dynamic Stability Improvement of a Wind Farm Connected to Grid Using STATCOM", *Proceedings of 2008 5th International Conference on Electrical Engineering/Electronics, Computer, Telecommunications and Information Technology*, Krabi, 2008, pp. 1057-1060. doi: 10.1109/ECTICON.2008.4600614
- [5] V. Chavhan and A. A. Ghute, "Stability Improvement of Wind Generation Using FACTS Device", *Proceedings of Technical Research Paper Competition for Students (TRPCS-2K17)*, 23 March 2017, G. H. Raisoni College of Engineering and Management, Amravati, Maharashtra, India. Retrieved from <https://www.ijsr.net/conf/TRPCS2017/TRPCS2K17-15.pdf>
- [6] V. Patel and R. K. Paliwal, "A Study on Improvement of the Transient Stability Using STATCOM in DFIG Based Wind Farm", *International Journal of Modern Trends in Engineering and Research*, Vol. 2, Issue No. 3, March 2015. Retrieved from <https://www.ijmter.com/papers/volume-2/issue-3/a-study-on-improvement-of-the-transient-stability-using-statcom-in-df.pdf>
- [7] M. Amiri and M. Sheikholeslami, "Transient Stability Improvement of Grid Connected Wind Generator Using SVC and STATCOM", *Proc. of International conference on Innovative Engineering Technologies (ICIET'2014)*, Dec. 28-29, 2014, Bangkok (Thailand). Doi: org/10.15242/IE.E1214025
- [8] V. S. Kumar, A. F. Zobaa, R. D. Kannan and K. Kalaiselvi, "Power Quality and Stability Improvement in Wind Park System Using STATCOM", *Jordan Journal of Mechanical and Industrial Engineering*, Vol. 4, Issue No. 1, pp. 169-176. Retrieved from <http://jjmie.hu.edu.jo/files/v4n1/24.pdf>
- [9] S. Gupta, R. K. Tripathi and R. D. Shukla, "Voltage Stability Improvement in Power Systems using Facts Controllers", *2010 International Conference on Power, Control and Embedded Systems*, Allahabad, 2010, pp. 1-8. Doi: 10.1109/ICPCES.2010.5698665
- [10] M. K. Deshmukh and C. B. Moorthy, "Review on Stability Analysis of grid connected Wind Power Generating System", *International Journal of Electrical and Electronics Engineering Research and Development (IJEEERD)*, Vol. 3, Issue No.1, pp.01-33, Jan-March 2013. Retrieved from <https://pdfs.semanticscholar.org/df55/0094415823206090dfacdac11a276d312449.pdf>
- [11] A. K. Mishra, R. Lekshmana, S. P. Chowdhury and S. Chowdhury, "Review of Wind Turbine System and its Impact for Grid Stability" *Journal of Electrical Engineering*, Vol. 11, Issue No. 1, 2011, pp. 153-165.