

# Transformer Oil Quality Diagnostic Using Spectroscopy Techniques - A Review

Hironmay Deb<sup>1</sup>, Javin Nunisa<sup>2</sup>, Mun moon sun Naiding<sup>3</sup>, Superdao Jidung<sup>4</sup>, Dipankar Sarmah<sup>5</sup>

<sup>1,2,3,4,5</sup>Department of Electrical and Electronics Engineering, School of Technology, Assam Don Bosco University  
Airport Road, Azara, Guwahati-781017, Assam, INDIA

<sup>1</sup>deb.hironmay@gmail.com\*, <sup>2</sup>javinunisa@gmail.com, <sup>3</sup>naiding29@gmail.com, <sup>4</sup>superdao23@gmail.com, <sup>5</sup>sarmahdipankar3@gmail.com

**Abstract:** Transformer serves as a vital component in the electrical energy supply system. In order to have an uninterrupted power supply, it is essential to timely monitor the condition of the transformer. A transformer has many components, out of which the transformer oil is one of the most crucial. It provides insulation and keeps the transformer cool. With ageing, the quality of the transformer oil degrades, and it loses its insulation properties that become a threat to the supply system. Optical Spectroscopy has gained a lot of attention in monitoring the quality of transformer oil in the past few years for various advantages. This paper reviews some of the commonly applied Spectroscopy techniques to monitor the various components of transformer oil by which we can predict the quality of the oil.

**Keywords:** Optical method; Spectroscopy; Transformer oil; DGA (Dissolve Gas Analysis); CLRS.

Open Access. Copyright ©Authors(s) and AJEEE. Distributed under the [Creative Commons Attribution 4.0 International License \(CC-BY\)](https://creativecommons.org/licenses/by/4.0/). Article history: Received: 1 Feb 2019 and Accepted: 15 March 2019.

## 1. Introduction

Power Transformers are one of the most vital elements in the transmission and distribution network. It is also the costliest instrument in the power system. To continue the power supply system, it is essential to monitor the condition of transformers continuously. Oil in a transformer serves as a coolant and provides insulation between the different parts [1-2]. Under continuous working conditions and with ageing the quality of transformer oil degrades [3]. Therefore, it becomes very crucial to timely monitor the quality of oil to prevent any kind of catastrophic failure. Quality monitoring of transformer oil involves the testing of various parameters of transformer oil such as moisture content, acidity, breakdown voltage, dielectric dissipation factor and interfacial tension [4]. Dissolved Gas Analysis (DGA) is one of the most widely used techniques [5]; however due to need in expertise and complex setup requirement, optical techniques are considered as an alternative. Optical fibre system is used as an alternative to electrical techniques [6-7]. Recently, various spectroscopy techniques are under research to develop other optical techniques to access the various parameters of transformer oil [8-9]. This paper describes the various spectroscopy techniques used to study the various parameters considered to monitor the quality of transformer oil.

## 2. Fundamental of Optical Spectroscopy

Optical Spectroscopy technique studies the interaction between a matter and electromagnetic wave (EM) [10]. The matter reflects, absorbs, diffuses, refracts or emits at particular wavelengths whenever an EM wave interacts with a matter. The readings obtained using spectroscopy techniques are accurate. In the UV-VIS-NIR spectroscopy techniques, light is passed through a sample under test and is detected in terms of optical signal, transmittance or reflectance. The results are then converted to absorbance as a function of wavelength given by Beer-Lambert Law [11] as

$$A_{\lambda} = -\log_{10} \left( \frac{S_{\lambda} - D_{\lambda}}{R_{\lambda} - D_{\lambda}} \right) = \epsilon_{\lambda} \cdot c \cdot l \quad (1)$$

where,  $A_{\lambda}$  is the light absorbance,  $S_{\lambda}$  is the sample intensity,  $R_{\lambda}$  is the reference intensity  $D_{\lambda}$  is the dark intensity,  $\epsilon_{\lambda}$  is the absorbance coefficient of the absorbing species at wavelength  $\lambda$ ,  $c$  is the concentration of the absorbing species (gram/liter) and  $l$  is the path length traversed by the light.

The spectrum of spectroscopic techniques is divided into Ultraviolet region, Visible Region and Infrared Region. This paper describes the spectroscopy techniques one by one.

Types of Spectroscopic Techniques used for monitoring transformer oil quality are:

- UV-VIS Spectroscopy
- NIR Spectroscopy
- Conical Laser Raman Spectroscopy (CLRS)

### 2.1 UV-Vis Spectroscopy

UV-VIS Spectroscopy is used commonly nowadays to monitor the change in various parameters in transformer oil. The system used is simple, robust and user-friendly methods compared to conventional Dissolved Gas Analysis (DGA) methods that require special expertise for testing. In literature, numerous methods have been described using UV-VIS Spectroscopy [12-13]. In this paper, some of the common setup use for spectroscopy is described.

In a method, the quality of inhibitors present in transformer oil was studied using UV-VIS Spectroscopy [14]. The organic chemical compounds known to retard oxidation in insulating oil are known as inhibitors [15]. There are various inhibitor such as 1,2,3-Benzotriazol (BTA), 2,6-ditertiarybutyl-para-cresol (DBPC), Nphenyl-1-naphthylamine and methylated-BTA, 2-tert-butyl-p-cresol (2-t-BPC), dibenzyl disulfide (DBDS), 2,6-ditertiarybutyl phenol (DBP). Out of these DBPC is the most universally accepted and desired inhibitor material in transformer oil. These inhibitors deplete over a period of time, which results in a degradation in transformer oil quality. Therefore, it becomes very necessary to timely monitor these inhibitor contents with proper sensing techniques.

Spectroscopy technique determined the weight percentage of inhibitor in the transformer oil. Different weights of Inhibitor content in oil was studied using the spectrometer setup shown in Figure 1.

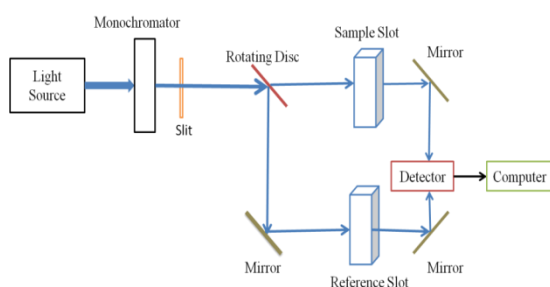
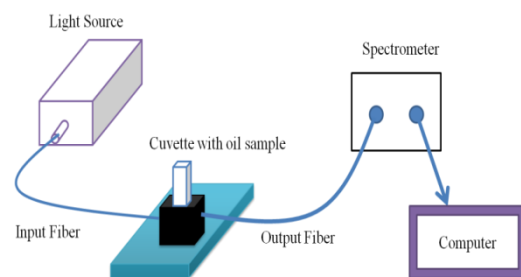

**Figure 1:** Block diagram of double beam spectrometer [14]

Optical absorbance was studied using the above setup. Using a rotating disc light was allowed to

pass through the sample slot and reference slot. The ratio between the sample absorbance and reference gave the absorbance for various samples tested. It was found that the sample at 1403nm gave the best absorbance, so a single wavelength source photodetector was aimed to make the system low cost and portable [14]. The system model designed showed a correlation between %IC in transformer oil and the peak absorbance wavelength.

In another work, the interfacial tension (IFT) of insulating oil was studied using UV-VIS spectroscopy [16]. IFT value is a marker for products of degradation and soluble polar contaminants [17]. These affect the physical and electrical properties of transformer oil by reducing the insulating properties. IFT value is determined by the amount of force required to separate a planar ring of platinum wire one centimetre through water/oil interface as stated in ASTM D971 (Interfacial Tension of Oil against Water by the Ring Method). The setup to calculate IFT value is a mechanical process that requires many precautions and standard procedures to be followed. As the setup is highly sensitive, there are high chances of mechanical errors. Instead of mechanical setup, the optical procedure provides a powerful and non-destructive technique for ITF measurement. A UV-spectroscopy setup, as shown in Figure 2, was used to measure the absorbance of 50 different samples of transformer oil [16]. The method eliminates the use of mirrors, making the system flexible and compact. Light from the source is allowed to pass through the oil sample, which is then collected by an optical fibre as input to the spectrometer. The light then interacts with the oil sample, due to the presence of various contaminants some of the light at particular wavelengths is absorbed by the oil sample. The absorbance is calculated by the Beer-Lambert Law.



**Figure 2:** Experimental setup for UV-Vis Spectroscopy [16].

The absorbance of oil samples for different IFT was plotted and found that a correlation was found that with increasing absorbance, there is a decrease in IFT number.

Artificial Neural Network (ANN) was used to calculate the correlation between IFT of transformer oil and its spectral response parameters like bandwidth and peak absorbance. The bandwidth and peak absorbance of oil spectral response are extracted and provided to the proposed ANN estimation model. The results show that UV-VIS spectroscopy technique gave comparable results when compared to commercial ASTM D971 (Interfacial Tension of Oil against Water by the Ring Method) standard. The UV-VIS spectroscopy method is found to be accurate, cheaper and user-friendly as compared to ASTM D971 standard method.

UV-VIS Spectroscopy conducted gave data about the physical condition of transformer oil along with dissolved decay products generated in the oil samples. However, no information could be extracted about the functional groups and molecular structure of the organic compounds in the transformer oil. In this regard, Alshehawry *et al.* used UV-VIS spectroscopy along with FTIR spectroscopy for condition assessment of transformer oil [18]. UV-VIS spectroscopy and FTIR spectroscopy were compared by using aged samples of oil. The UV-VIS spectroscopy covers a wavelength range from 200nm to 800nm whereas the FTIR spectroscopy extends the range from 2.5 $\mu$ m to 25 $\mu$ m. Mineral transformer oil consists of a complex of paraffins, naphthenes and aromatic hydrocarbon. Out of them, aromatic hydrocarbon absorbs energy in the UV range from 200nm to 380nm. The peaks that appear in the spectrum were resulted due to conjugated C=O bond and C=C d=bonds that show response at two different wavelength values. The absorbance peaks shifted to higher wavelengths with the ageing of the transformer oil. Whereas, FTIR spectra are used to identify the difference in the functional groups.

S. Karmakar *et al.* used UV-VIS spectroscopy techniques to study the insulation properties of transformer oil [19]. There are various factors such as electric arcing, partial discharge (PD), thermal ageing, which contribute to the degradation of oil quality. In this method, they studied the degradation due to PD, which were marked by sharp peaks at nearly 293nm and 306nm. The schematic of the setup is shown in Figure 3.

PD is generated in the setup using needle-flat electrode. The magnitude of PD is varied according to the supplied voltage. Four samples of transformer oil were prepared namely S1,S2,S3,S4 where S1 for new transformer oil,S2 for transformer oil aged by PD and S3 transformer oil aged by electric arcing with 500 numbers of shots, and S4 transformer oil aged by thermal effects by

heating new transformer oil at 120°C for 1h respectively.

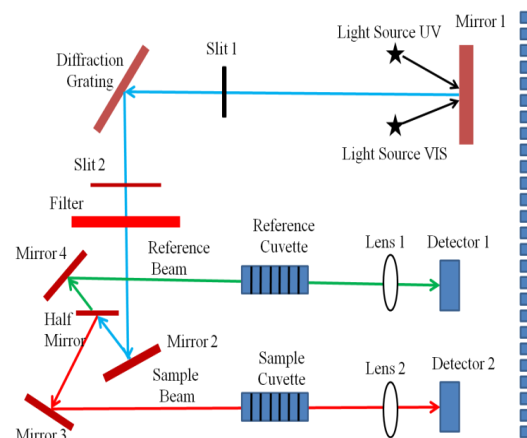

**Figure 3:** The schematic diagram of the optical absorption measurement in the UV-VIS spectrometer [18].

The ageing of transformer oil increases the aromatic content and acidity, which gives rise to C=O and C=C double bond. Due to ageing the paraffin compounds of the transformer oil dehydrogenate and result in the formation of naphthenic compounds. Further, dehydrogenation of the naphthenic compounds forms conjugated C=C double bonds. These chemical processes also result in colour change in the transformer oil. The changes in the characteristic of the transformer oil are depicted easily using the UV-VIS spectroscopy method, which results to be an effective way of monitoring the quality of oil with ageing.

The above literature studies of methods to monitor transformer oil quality with ageing shows a similar trend in the absorption spectrum where typically in a wavelength range from 280nm to 400nm the absorption peak appears. So, designing a setup with a far UV light source or targeting a single source of light for studying the oil quality may be taken into account to make the setup more compact and low cost.

## 2.2 NIR Spectroscopy

NIR Spectroscopy has been implemented to study the degradation of transformer oil. Borges *et al.* proposed a method to analyze the chemical degradation of mineral insulation oil [20]. A prototype that adapts on Buchholz transformer relay using the Near Infrared Spectroscopy with chemometrics techniques is used to analyze light gaseous hydrocarbons (methane, ethane, ethylene and acetylene). The test was performed using 29 different samples and absorbance spectrum for all these samples was studied. High-intensity absorbance peak at 2300nm for all the samples

showed the regularity in the response of the samples. The magnitude of samples for different concentration of gases is different, but the peak wavelength remains almost the same. Therefore, an intensity-based prototype can be designed that used to monitor the gaseous contents in transformer oil.

In another method, Attenuated Total Reflectance Tool (ATR) was used to detect the effect of Thermal Oxidation and Nitration in the deterioration of quality of transformer oil [21]. The principle of ATR technique is shown in Figure 4.

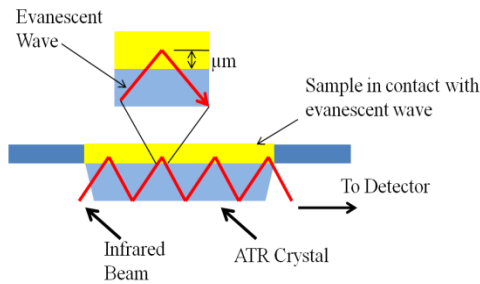

Figure 4: Principle of ATR technique [21]

The sample under test is placed on a detection crystal and a part of IR ray causes absorption in the sample when passing through the crystal sample interface (evanescent wave) and weakens this part in the resultant spectrum. A peak intensity is shown in the NIR wavelengths where the absorption is due to Thermal Oxidation and Nitration.

### 2.3 Laser Raman Spectroscopy

Laser Raman Spectroscopy (LRS) is based on the Raman Effect, which was discovered by C. V Raman in 1928. The structures and properties of matter can be estimated by directly measuring the Raman scattering light produced by matter due to irradiation. Photons of incident light are absorbed by the electron in a gas molecule with  $h\nu_0$  energy, which is the Rayleigh scattering light without any change in frequency. An energy of  $h(\nu_0 + \Delta\nu)$  is released by another part of the electrons that return to the vibration excited state. This is the Raman scattering light with the frequency change. The transition is shown in Figure 5.

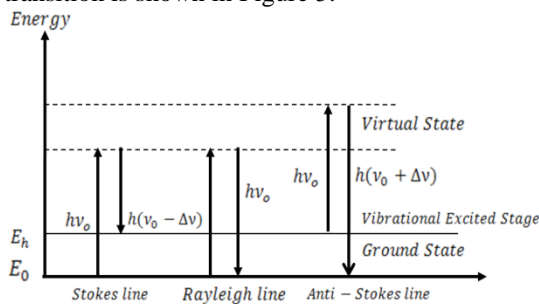

Figure 5: Raman scattering process

The change in frequency  $\Delta\nu$  of the Raman scattering is called Raman shift. The structural information of the molecules can be predicted from this Raman shift, which corresponds to the fundamental frequency of the vibration mode of the molecule. The gas concentration is proportional to the peak intensity of the Raman spectrum. So, without separating the mixture of gases we can get the composition and concentration of the gas by analyzing the Raman shift and peak intensity.

The intensity of the Raman scattering is given by the formula

$$I_R = \frac{2^4 \pi^3}{45 \times 3^2 C^4} \times \frac{h I_L N (\nu_0 - \nu)^4}{\mu \nu \left(1 - e^{-\frac{h\nu}{kT}}\right)} \times [45 (\alpha'_a)^2 + 7 (\gamma'_a)^2] \dots (2)$$

where  $c$  is the speed of light,  $h$  is the Plank's constant,  $I_L$  is the excitation light intensity,  $N$  is the number of molecules scattering light,  $\nu$  is the vibration frequency of the molecule in Hz,  $\nu_0$  is the laser frequency in Hz,  $\mu$  is the reduced mass of vibration atom;  $K$  is the Boltzmann's constant,  $T$  is the absolute temperature,  $\alpha'_a$  is the average invariant of polarizability tensor,  $\gamma'_a$  is the isotropic invariant of polarizability tensor.

Laser Raman Spectroscopy technique was adapted to measure the dissolved  $C_2H_2$  gas concentrations present in transformer oil [22]. As shown in Figure 6, a frequency doubled Q-switched Nd:YAG laser (532nm) was used as a source and the signals were detected 1.972 $\mu$ m originating from  $C_2H_2$  gas.

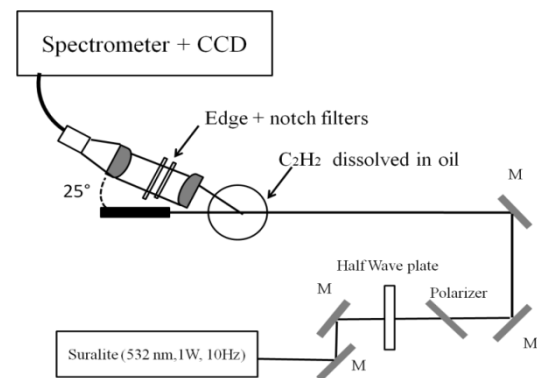
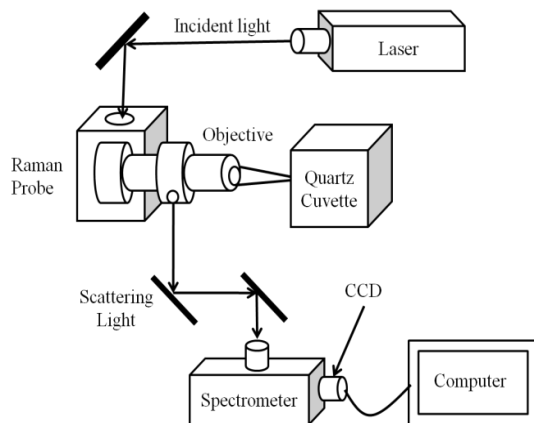

Figure 6: Schematic diagram of experimental setup [22].

The intensity peaks were detected at 1450 $cm^{-1}$ . These were due to  $CH_3-CH_2$  bonds, peaks at 1302 and 1350  $cm^{-1}$  correspond to paraffin C-H twisting modes, peaks at 1610  $cm^{-1}$  is due to an aromatic C=C stretching mode. The various peaks can be selectively chosen to get a better response for any particular component of bonds. The Raman Spectroscopy opens new techniques, which are very sensitive methods to detect changes in the components of transformer oil.



In practical applications, the sensitivity of the current LRS detection method cannot meet the required efficiency in engineering applications [24]. To meet this requirement, Conical Laser Raman Spectroscopy (CLRS) was adopted. The setup of CLRS using a Raman probe, as shown in Figure 7.



**Figure 7:** Schematic of CLRS Experimental Setup [25].

Gu *et al.* proposed a method for Conical Laser Raman Spectroscopy (CLRS) detection characteristic of acetone dissolved in transformer oil [25]. The figure below shows the setup using a 532 nm solid-state laser along with a CCD based spectrometer. A quartz cuvette was filled with different oil samples, and the response was analyzed for Raman peaks. Multiple Raman Peaks were observed along the spectrum, out of which a peak at  $780\text{ cm}^{-1}$  had the highest intensity for acetone. Different samples of acetone dissolved in transformer oil were studied at  $780\text{ cm}^{-1}$ . This process opened a new approach of using CLRS method that is simpler and provides faster, non-touch and non-destructive detection compared to conventional methods.

Another compound in the transformer oil, Furfural (Furan 2-carbaldehyde) that is regarded as an important marker for the thermal and mechanical degradation in oil-paper insulation can be monitored using CLRS [25].

Raman peaks at five different wavelengths at 1371, 1399, 1471, 1677 and  $1699\text{ cm}^{-1}$  were detected for Furfural.

Conventional Raman enhancement methods, such as Resonance Raman Spectroscopy [26], Tip-Enhanced Raman Spectroscopy [27], and Surface-Enhanced Raman Spectroscopy [28] appear to be inadequate for monitoring gases in transformer oil. Compared to conventional methods CLRS has high intensity and better efficiency. CLRS also makes the system compact and accurate.

Raman Spectroscopy was applied to analyze many other compounds in transformer oil like methyl formate [29], Oil-paper insulation [30], and methanol [31].

### 3. Conclusion

Even though DGA is one of the most popular methods of transformer fault diagnostic but as it is laboratory-based testing system that required a certain amount of time for analysis, along with the expertise of testing, Optical Spectroscopy methods have taken the lead in overcoming these difficulties. Due to high sensitivity and ability to make a compact and low-cost detection system using optical components, Spectroscopy techniques are now more researched for application in transformer fault analysis.

### References

- [1] J. A. Palmer, Xianghui Wang, R. A. Shoureshi, A. Mander, D. Torgerson and C. Rich, "Effect of aging on the spectral response of transformer oil", *Proc. of Conference Record of the 2000 IEEE International Symposium on Electrical Insulation (Cat. No.00CH37075)*, Anaheim, CA, USA, 5 April 2000, pp. 460-464. Doi: 10.1109/ELINSL.2000.845548
- [2] A. A. Suleiman, N. A. Mohamad, N. Bashir, A. S. Alghamdi and M. Aizam, "Improving accuracy of DGA interpretation of oil-filled power transformers needed for effective condition monitoring" *Proc. of 2012 IEEE International Conference on Condition Monitoring and Diagnosis*, Bali, 23-27 Sept. 2012, pp. 374-378. Doi: 10.1109/CMD.2012.6416458
- [3] J. Wada, G. Ueta, S. Okabe and T. Amimoto, "Inhibition technique of transformer insulating oil degradation - evaluation of the effectiveness of oxidation degradation inhibitors", *IEEE Transactions on Dielectrics and Electrical Insulation*, Vol. 20, Issue 5, Oct. 2013, pp. 1641-1648. Doi: 10.1109/TDEI.2013.6633694
- [4] M. Kohtoh, G. Ueta, S. Okabe and T. Amimoto, "Transformer insulating oil characteristic changes observed using accelerated degradation in consideration of field transformer conditions", *IEEE Transactions on Dielectrics and Electrical Insulation*, Vol. 17, Issue 3, June 2010, pp. 808-818. Doi: 10.1109/TDEI.2010.5492254

- [5] S. A. Ward, "Evaluating transformer condition using DGA oil analysis", *Proc. of 2003 Annual Report Conference on Electrical Insulation and Dielectric Phenomena*, Albuquerque, NM, USA, 19-22 Oct. 2003, pp. 463-468. Doi: 10.1109/CEIDP.2003.1254893
- [6] P. Lu *et al.*, "Real-time monitoring of temperature rises of energized transformer cores with distributed optical fiber sensors", *IEEE Transactions on Power Delivery*, April 2019. Doi: 10.1109/TPWRD.2019.2912866
- [7] A. Razzaq, H. Zainuddin, F. Hanaffi and R. M. Chyad, "Transformer oil diagnostic by using an optical fibre system: a review", *IET Science, Measurement & Technology*, Vol. 13, Issue 5, July 2019, pp. 615-621. Doi: <https://doi.org/10.1049/iet-smt.2018.5076>
- [8] A. Abu-Siada, S. P. Lai and S. M. Islam, "A Novel Fuzzy-Logic Approach for Furan Estimation in Transformer Oil", *IEEE Transactions on Power Delivery*, Vol. 27, Issue 2, pp. 469-474, April 2012. Doi: 10.1109/TPWRD.2012.2186986
- [9] D. Skelly, "Photo-acoustic spectroscopy for dissolved gas analysis: Benefits and Experience", *Proc. of 2012 IEEE International Conference on Condition Monitoring and Diagnosis*, Bali, 23-27 Sept. 2012, pp. 29-43. Doi: 10.1109/CMD.2012.6416446
- [10] N. A. Bakar, A. Abu-Siada, N. Das and S. Islam, "Effect of Conducting Materials on UV-Vis Spectral Response Characteristics", *Universal Journal of Electrical and Electronic Engineering*, Vol. 1, Issue 3, 2013, pp. 81-86. doi: 10.13189/ujeee.2013.010304
- [11] L. H. Bowman, "A simple, effective introduction to the Beer-Lambert relationships", *Journal of Chemical Education*, Vol. 59, Issue 2, Feb. 1982, pp.155. Doi: <https://doi.org/10.1021/ed059p155.2>
- [12] N. A. Baka, A. Abu-Siada, S. Islam and M. F. El-Naggar, "A new technique to measure interfacial tension of transformer oil using UV-Vis spectroscopy", *IEEE Transactions on Dielectrics and Electrical Insulation*, Vol. 22, Issue 2, April 2015, pp. 1275-1282. Doi: 10.1109/TDEI.2015.7076831
- [13] Y. Hadjadj, I. Fofana, J. Sabau and E. Briosso, "Assessing insulating oil degradation by means of turbidity and UV/VIS spectrophotometry measurements", *IEEE Transactions on Dielectrics and Electrical Insulation*, Vol. 22, Issue 5, October 2015, pp. 2653-2660. Doi: 10.1109/TDEI.2015.005111
- [14] L. Y. Sing *et al.*, "Determining the inhibitor content of transformer insulating oil using UV-Vis spectroscopy", *Proc. of 2016 6<sup>th</sup> IEEE International Conference on Control System, Computing and Engineering (ICCSCE)*, Batu Ferringhi, 25-17 Nov. 2016, pp. 179-183. Doi: 10.1109/ICCSCE.2016.7893567
- [15] K. Baburao, D. Shukla and N. Nanavati, "Depletion rate of oxidation inhibitor in hydroprocessed mineral insulating oil and naphthenic oils", *Proc. of 2012 IEEE International Conference on Condition Monitoring and Diagnosis*, Bali, 23-27 Sept. 2012, pp. 261-264. Doi: 10.1109/CMD.2012.6416426
- [16] N. A. Baka, A. Abu-Siada, S. Islam and M. F. El-Naggar, "A new technique to measure interfacial tension of transformer oil using UV-Vis spectroscopy", *IEEE Transactions on Dielectrics and Electrical Insulation*, Vol. 22, Issue 2, April 2015, pp. 1275-1282. Doi: 10.1109/TDEI.2015.7076831
- [17] H. Gumilang, "Unique relationship between interfacial tension test (IFT) and neutral number test (Acidity) of transformer insulation oil in PLN P3B JB - Jakarta and Banten Regional", *Proc. of 2009 IEEE 9th International Conference on the Properties and Applications of Dielectric Materials*, Harbin, 19-23 July 2009, pp. 29-32. Doi: 10.1109/ICPADM.2009.5252513
- [18] K. Hussain and S. Karmakar, "Condition assessment of transformer oil using UV-Visible spectroscopy", *Proc. of 2014 Eighteenth National Power Systems Conference (NPSC)*, Guwahati, 18-20 Dec. 2014, pp. 1-5. Doi: 10.1109/NPSC.2014.7103841
- [19] S. Karmakar, N. K. Roy, P. Kumbhakar, "Effect of ageing in transformer oil using UV-visible spectrophotometric technique", *Journal of Optics*, Vol. 40, Issue 2, June 2011, pp. 33-38. Doi: <https://doi.org/10.1007/s12596-011-0030-4>
- [20] G. B. C. Borges, J. J. R. Rohwedder, E. C. Bortoni, "Evaluation of the use of Near Infrared Spectroscopy (NIR) in on-line Monitoring of Power Transformer Insulation Oil." *AASRI Procedia*, Vol. 2, 2012, pp. 56-61. Doi: <https://doi.org/10.1016/j.aasri.2012.09.014>

- [21] P. Prosr, R. Polansky and V. Mentlik, "Infrared spectroscopy of regenerated mineral insulating oil", *Annals of DAAAM for 2011 & Proceedings of the 22nd International DAAAM Symposium*, Vol. 22, Issue 1, pp. 31-32. Retrieved from [https://www.daaam.info/Downloads/Pdfs/proceedings/proceedings\\_2011/0031\\_Proshr.pdf](https://www.daaam.info/Downloads/Pdfs/proceedings/proceedings_2011/0031_Proshr.pdf)
- [22] T. Somekawa, M. Kasaoka, F. Kawachi, Y. Nagano, M. Fujita and Y. Izawa, "Analysis of dissolved C<sub>2</sub>H<sub>2</sub> in transformer oils using laser Raman spectroscopy", *Optics Letters*, Vol. 38, Issue 7, 2013, pp. 1086-1088. Doi: <https://doi.org/10.1364/OL.38.001086>
- [23] T. Somekawa, M. Fujita, Y. Izawa, M. Kasaoka and Y. Nagano, "Furfural analysis in transformer oils using laser Raman spectroscopy", *IEEE Transactions on Dielectrics and Electrical Insulation*, Vol. 22, Issue 1, Feb. 2015, pp. 229-231. Doi: [10.1109/TDEI.2014.004800](https://doi.org/10.1109/TDEI.2014.004800)
- [24] W. Chen, Z. Gu, J. Zou, F. Wan and Y. Xiang, "Analysis of furfural dissolved in transformer oil based on confocal laser Raman spectroscopy", *IEEE Transactions on Dielectrics and Electrical Insulation*, Vol. 23, Issue 2, April 2016, pp. 915-921. Doi: [10.1109/TDEI.2015.005434](https://doi.org/10.1109/TDEI.2015.005434)
- [25] Z. Gu, W. Chen, L. Du, H. Shi and F. Wan, "Application of Raman Spectroscopy for the Detection of Acetone Dissolved in Transformer Oil", *Journal of Applied Spectroscopy*, Vol. 85, Issue 2, 2018, pp. 225-231. Doi: [10.1007/s10812-018-0636-2](https://doi.org/10.1007/s10812-018-0636-2)
- [26] C. Fantini, A. Jorio, M. Souza, M. S. Strano, M. S. Dresselhaus and M. A. Pimenta, "Optical Transition Energies for Carbon Nanotubes from Resonant Raman Spectroscopy: Environment and Temperature Effects", *Physical Review Letters*, Vol. 93, Issue 14, 2004, pp. 147406. Doi: <https://doi.org/10.1103/PhysRevLett.93.147406>
- [27] B. Pettinger, B. Ren, G. Picardi, R. Schuster and G. Ertl, "Nanoscale probing of adsorbed species by tip-enhanced Raman spectroscopy", *Physical Review Letters*, Vol. 92, Issue 9, 2004, pp. 096101. Doi: <https://doi.org/10.1103/PhysRevLett.92.096101>
- [28] M. K. K. Oo, Y. Guo, K. Reddy, J. Liu and X. Fan, "Ultrasensitive Vapor Detection with Surface-Enhanced Raman Scattering-Active Gold Nanoparticle Immobilized Flow-Through Multihole Capillaries", *Analytical Chemistry*, Vol. 84, Issue 7, 2012, pp. 3376-3381. Doi: <https://doi.org/10.1021/ac300175v>
- [29] Z. Gu, W. Chen, L. Du, J. Zou and F. Wan, "Analysis of methyl formate dissolved in transformer oil by laser Raman spectroscopy", *Proc. of 2016 IEEE International Conference on Power System Technology (POWERCON)*, Wollongong, NSW, 28 Sept.-1 Oct. 2016, pp. 1-4. Doi: [10.1109/POWERCON.2016.7753956](https://doi.org/10.1109/POWERCON.2016.7753956)
- [30] J. Zou, W. Chen, F. Wan, Z. Fan and L. Du, "Raman Spectral Characteristics of Oil-Paper Insulation and Its Application to Ageing Stage Assessment of Oil-Immersed Transformers", *Energies*, Vol. 9, Issue 11, 2016, pp. 946. Doi: <https://doi.org/10.3390/en9110946>
- [31] Z. Gu, W. Chen, Y. Xiang, L. Du, F. Wan and L. Zhao, "Detection of methanol dissolved in transformer oil by laser Raman spectroscopy", *Proc. of 2016 IEEE International Conference on High Voltage Engineering and Application (ICHVE)*, Chengdu, 19-22 Sept. 2016, pp. 1-4. Doi: [10.1109/ICHVE.2016.7800729](https://doi.org/10.1109/ICHVE.2016.7800729)

## Authors' Profiles

**Hironmay Deb**, is working as an Assistant Professor in the department of Electrical and Electronics Engineering at Assam Don Bosco University.



**Javin Nunisa**, is currently Pursuing Bachelor degree in Electrical and Electronics Engineering (final semester), Assam Don Bosco University.



**Mun moon sun Naiding**, is currently pursuing Bachelor degree in Electrical and Electronics Engineering (final semester), Assam Don Bosco University.



**Superdao Jidung**, is currently pursuing Bachelor degree in Electrical and Electronics Engineering (final semester), Assam Don Bosco University.



**Dipankar Sarmah**, is currently pursuing Bachelor degree in Electrical and Electronics Engineering (final semester), Assam Don Bosco University.

